



C.R.I. PUMPS
Pumping trust. Worldwide.

High
performance
sewage and
drainage pumps
to meet a
wide range of
applications

MAKE A CLEAN JOB OF IT



WASTE WATER SUBMERSIBLE PUMPS - 50Hz

C.R.I. PUMPS (PVT) LIMITED

(International Division)

7/46-1, Keeranatham Road, Saravanampatty, Coimbatore - 641 035. Tel : +91-422-3911610, 3911612.
Fax : +91-422-3911600 e-mail : cri@criexports.com website: www.cripumps.com

C.R.I. PUMPS S.A. (PTY) LIMITED

P.O. Box 6292, Halfway House, Midrand - 1685, Johannesburg,
South Africa. Tel : +27-11-8058631 / 32 Fax : +27-11-8058630
e-mail : cri@cripumps.co.za website : www.cripumps.co.za

**C.R.I. POMPA SANAYİ VE TİCARET
LİMİTED ŞİRKETİ**

10032 Sk. No:12 A.O.S.B. 35620 Çiğli-Izmir-Türkiye.
Tel:+90-232-328 22 99 Fax:+90-232-328 23 33
E-mail: cri@cripompa.com Website: www.cripompa.com

C.R.I. PUMPS (FZE)

P.O. Box 7988, A4-40 SAIF-Zone, Sharjah, U.A.E.
Tel : +971-6-5573041 (3 Lines), Fax : +971-6-5573042
e-mail : cripumps@eim.ae

C.R.I. BOMBAS HIDRÁULICAS LTDA

Av. Rodrigo Fernando Grillo, 457, Jd. Manacas,
CEP - 14.801-534, Araçuaçuara - SP, Brasil.
Fone : +55-16-3331 1099, Fax +55-16-3331 5344
e-mail : cri@cribombas.com.br website : www.cribombas.com.br

BOMBAS C.R.I. ESPAÑA,S.L.

Poligono Industrial El Bony Calle 31, No.137, 46470 Catarroja(Valencia) Spain.
Tel: +34-96 1842 974 Fax: +34-96 1842 977. Email: cri@bombascri.es Website: www.bombascri.es

EC-30511-10/1,2,ES

An ISO 9001 & ISO 14001 Company



C O N T E N T S

	PageNo.
Model identification Code	02
General Information	03
SEWAGE PUMPS	
SM & SH Series - Cast Iron Medium & Heavy Sewage Pumps	
Specifications & M.O.C.	04
Cross Sectional Drawing	05
Performance Table	06
Performance Curves	07
Dimensional Details	12
SMC Series - Cast Iron Sewage Pump with cutter	
Specifications, M.O.C., Performance Table & Curves	13
SMS Series - Stainless Steel Medium Sewage Pumps	
Specifications, M.O.C.	14
Performance Table & Performance Curves	15
Dimensional Details	18
Guide Rail System	19
DRAINAGE PUMPS	
DMS Series - Stainless Steel Drainage Pumps	
Specifications, M.O.C. & Performance Table	20
Performance Curves	21
DM Series - Submersible Drainage Pumps	
Specifications, M.O.C. & Performance Table	23
Performance Curves	24
Cut Sectional Drawing & Dimensional Details	26
DMA Series - Submersible Slurry Pumps	
Specifications, M.O.C. & Performance Table	27
Performance Curves	27
Cut Sectional Drawing & Dimensional Details	28

Model Identification Code - Waste Water Pumps

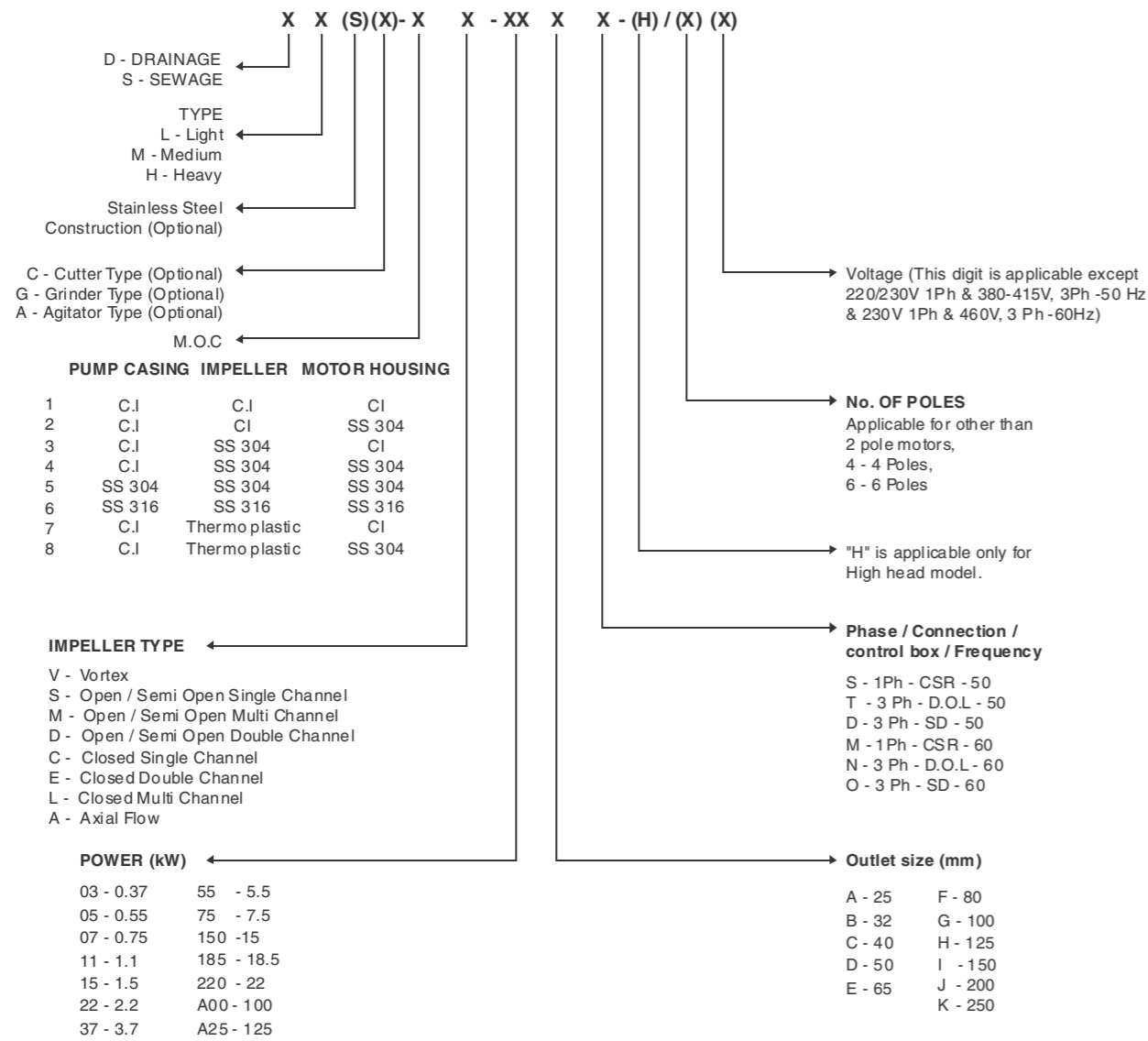

Description

DMA - 2D - 60GT/4 : 6 kW - 3 Phase 4Pole, 4" outlet Medium Drainage Pump with Agitator & Open Double Channel Impeller.
 SMS - 5E - 75GT : 7.5 kW - 3 Phase 2Pole, 4" outlet Stainless steel Medium Sewage Pump with SS Closed Double Channel Impeller.
 SH - 5E - 110ET : 110 kW - 3 Phase 2Pole, 2½" outlet Heavy Drainage Pump with Closed Double Channel Impeller.



C.R.I. WASTE WATER SUBMERSIBLE PUMPS

With the excellence gained in pump technology over the period of 50 years C.R.I. has introduced highly efficient and reliable sewage & drainage pumps in a comprehensive range. These pumps are available with different materials of construction and feature a multitude of applications in waste water handling and treatment.

Besides expanding its product portfolio, C.R.I. is firmly committed to contribute a vital role in creating a more pleasant and affluent living condition world wide, which is one among its ambitious goal.

All C.R.I. drainage & sewage pumps are perfectly powered by motors designed to deliver optimal performance and to withstand vagaries of weather and power fluctuation.

C.R.I. 's well equipped R&D coupled with the latest engineering software & technology, highly flexible production facilities, stringent, integrated & modern quality control systems well tuned logistics system & steadfast work force ensure delivery of high standard and flawless products. Proven performance, functional design, quality and after sales support ensure trouble free operation year after year.

Features

International standard design | Auto cut | Silicon Carbide / Tungsten Carbide mechanical seal | SS | good quality and performance.

Multiple impeller design to handle different sewage & waste water.

Full range from low head to high head, Compact & easy installation, Equipped with guide rail system.

Applications

Draining sewage water from hotels, houses, commercial buildings complexes etc | Pumping waste water in industries | Tunnel and mines | Pumping sewage water from stock farms & manhole sewer | Sewage treatment plants | Pumping municipal sewage water | Septic tank | Leather factories | Aquaculture water supply and drainage | Dewatering in construction sites | Water supply for agriculture irrigation, underground water pumping | Land scape and horticulture irrigation | Pumping of water from rivers & lakes

Medium and Heavy Sewage Pumps - SM & SH Series



Specifications

Pump Type	Medium Sewage - SM Series	Heavy Sewage - SH Series	
Power Range	2.2kW - 5.5 kW	5.5 kW - 15 kW	7.5 kW - 37 kW
Speed	2900 rpm	2900 rpm	1450 rpm
Version	380 ~ 415V, 3Ph, 50 Hz, AC Supply	380 ~ 415V, 3Ph, 50 Hz, AC Supply	
Degree of Protection	IP 68	IP 68	
Insulation Class	F	F	
Impeller Type	Closed Double Channel	Closed Double Channel	
Duty	S1	S1	
Direction of Rotation	Clockwise viewed from driving end	Clockwise viewed from driving end	
Max. Immersion Depth	5m	5m	
Max. Liquid temperature	40°C	40°C	
Max. Ambient temperature	40°C	40°C	
Permissible pH value	6 - 10	6 - 10	
Max. Solid Handling Capacity	upto 35 mm	upto 55 mm	
Pump Outlet Size	2", 2½", 3", 4"	2½", 3", 4", 6", 8" & 10"	

Materials of Construction

Pump Name	Material
Stator Housing	Cast Iron
Cable	H07RN - F
Rotor Shaft	SS 420
Bearing Housing	Cast Iron
Pump Casing	Cast Iron
Mechanical Seal	Hard Alloy vs Silicon
Impeller	Cast Iron
Bracket Casing	Cast Iron
"O" Ring	NBR
Oil Seal	NBR

*All Sewage pump models can be supplied along with guide rail system on request.
 *In view of continuous developments, the information / description / specifications / illustrations are subject to change without notice.

Cross Sectional Drawing

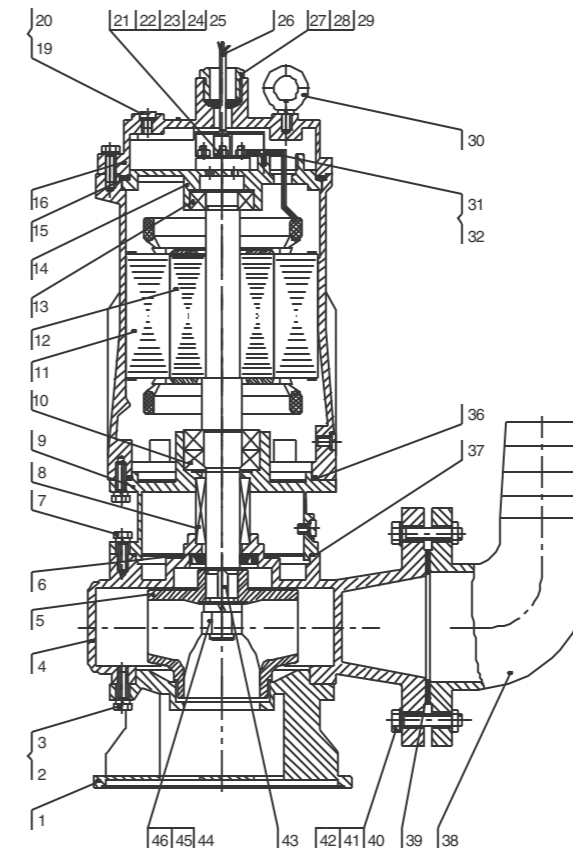

Part No.	Name
1	BASE
2	BOLT
3	SPRING WASHER
4	PUMP CASING
5	IMPELLER
6	MECHANICAL SEAL
7	BOLT
8	MECHANICAL SEAL
9	OIL CHAMBER
10	BEARING
11	STATOR
12	ROTOR
13	BEARING
14	BEARING HOUSING
15	SEAL WASHER
16	END COVER
19	SCREW
20	O-RING
21	NUT
22	STUD
23	WASHER
24	SCREW
25	TERMINAL BLOCK
26	CABLE
27	GROMMET NUT
28	GROMMET
29	SEAL JACKET
30	EYE BOLT
31	SCREW
32	SPRING WASHER
36	O-RING
37	O-RING
38	OUTLET ELBOW
39	GASKET
40	NUT
41	WASHER
42	BOLT
43	KEY
44	NUT
45	FLAT WASHER
46	SPRING WASHER

Performance Table - SM Series

Model	Power - P2		Input Power-P1 (kW)	Outlet size in inches	Solid Passage (mm)	H max in m	Duty Point		F.L. Current (A)	Eff. %	Weight (kg)
	kW	HP					Flow (m³/h)	Head (m)			
SM-1E-22DT	2.2	3	3	2	15	24	15	19.5	4.7	38	36
SM-1E-22ET	2.2	3	3	2½	25	20	25	13.5	4.7	53	36
SM-1E-22FT	2.2	3	3	3	25	14.5	40	9	4.7	45	38
SM-1E-30DT	3	4	4	2	20	31	15	27	6.4	37.5	50
SM-1E-30ET	3	4	4	2½	25	27.5	25	19.5	6.4	45	51
SM-1E-30FT	3	4	4	3	30	20.5	40	13	6.4	52	57
SM-1E-30GT	3	4	4	4	30	13.5	50	7	6.4	31	62
SM-1E-40DT	4	5.5	5	2	15	46.5	12.5	40	8.2	30.5	68
SM-1E-40ET	4	5.5	5	2½	25	38	25	28.5	8.2	39	68
SM-1E-40FT	4	5.5	5	3	30	31	30	25	8.2	47	68
SM-1E-40GT	4	5.5	5	4	35	19.5	50	11.5	8.2	41	70
SM-1E-55DT	5.5	7.5	7	2	20	53	12.5	46.5	11	37	83
SM-1E-55ET	5.5	7.5	7	2½	25	44	25	36	11	50	85
SM-1E-55FT	5.5	7.5	7	3	30	33	30	27	11	48	85
SM-1E-55GT	5.5	7.5	7	4	35	28	65	17	11	46	85

*In view of continuous developments, the information / description / specifications / illustrations are subject to change without notice.

Performance Table - SH Series

2900 RPM

Model	Power - P2		Input Power - P1 (kW)	Outlet size in inches	Solid Passage (mm)	H max in m	Duty Point		F.L. Current (A)	Eff. %	Weight (kg)
	kW	HP					Flow (m³/h)	Head (m)			
SH-1E-55IT	5.5	7.5	7	6	40	16	100	9.5	11	45.6	-
SH-1E-75ET	7.5	10	9.5	2½	20	42.5	30	36.5	15	41.5	138
SH-1E-75FT	7.5	10	9.5	3	30	32	65	23	15	61	138
SH-1E-75GT	7.5	10	9.5	4	30	28	45	21.5	15	42	129
SH-1E-75IT	7.5	10	9.5	6	40	22.5	100	13.5	15	50	130
SH-1E-110ET	11	15	14	2½	25	56.5	35	49	22	41	230
SH-1E-150ET	15	20	18.5	2½	25	62.5	35	54.5	29	44	250

1450 RPM

Model	Power-P2		Input Power-P1 (kW)	Outlet size in inches	Solid Passage (mm)	H max in m	Duty Point		F.L. Current (A)	Eff. %	Weight (kg)
	kW	HP					Flow (m³/h)	Head (m)			
SH-1E-75GT/4	7.5	10	9.5	4	35	21	80	18.5	15	54	126
SH-1E-75IT/4	7.5	10	9.5	6	35	16.5	100	10	15	38.5	160
SH-1E-110GT/4	11	15	13.8	4	35	28.5	100	23.5	22	72.6	230
SH-1E-110IT/4	11	15	13.8	6	45	21	130	18	22	70	250
SH-1E-150GT/4	15	20	18.5	4	35	39	100	30	29	57	260
SH-1E-150IT/4	15	20	18.5	6	45	24.5	180	18	29	64.8	272
SH-1E-150JT/4	15	20	18.5	8	45	15.5	250	9.5	29	65	271
SH-1E-185GT/4	18.5	25	22.5	4	35	43	100	34	36	49	305
SH-1E-185IT/4	18.5	25	22.5	6	35	27.5	180	24	36	68.72	323
SH-1E-185JT/4	18.5	25	22.5	8	55	27.5	250	18.5	36	66.5	349
SH-1E-220IT/4	22	30	26	6	45	33	180	27	42	66.23	360
SH-1E-220JT/4	22	30	26	8	50	33.5	350	17.5	42	59.73	364
SH-1E-300IT/4	30	40	36	6	40	36.5	180	28	57	59	370
SH-1E-300JT/4	30	40	36	8	50	36.5	250	26.5	57	65	380
SH-1E-300KT/4	30	40	36	10	50	16	600	9	57	62.33	600
SH-1E-370IT/4	37	50	43	6	40	42.5	200	31	70	63	650
SH-1E-370JT/4	37	50	43	8	45	39	350	27	70	82	509
SH-1E-370KT/4	37	50	45	10	55	23	600	12.5	70	65	588

*In view of continuous developments, the information / description / specifications / illustrations are subject to change without notice.

Performance Curves - SM Series

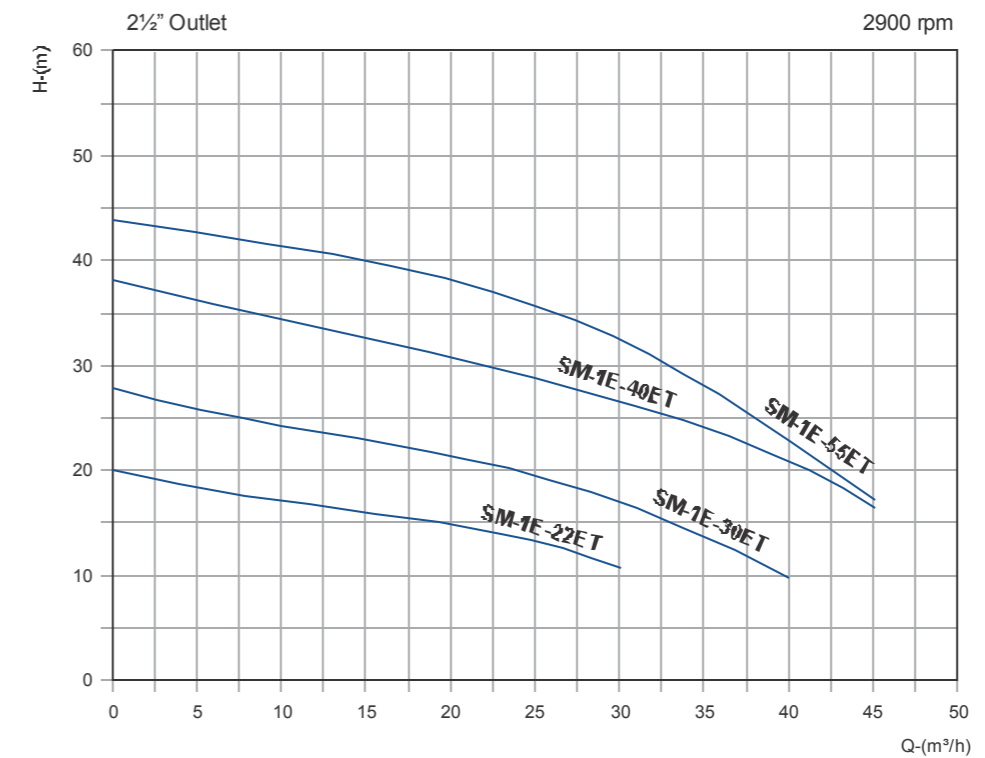
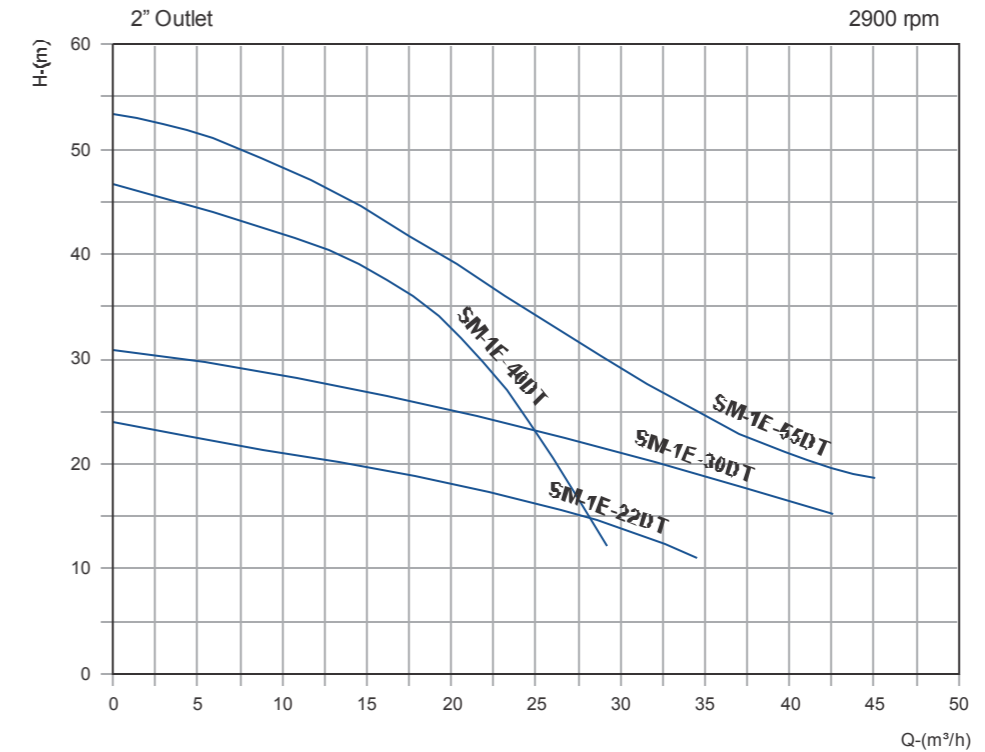

Note : Performance curve are as per specific gravity and viscosity of water.

Performance Curves - SM Series

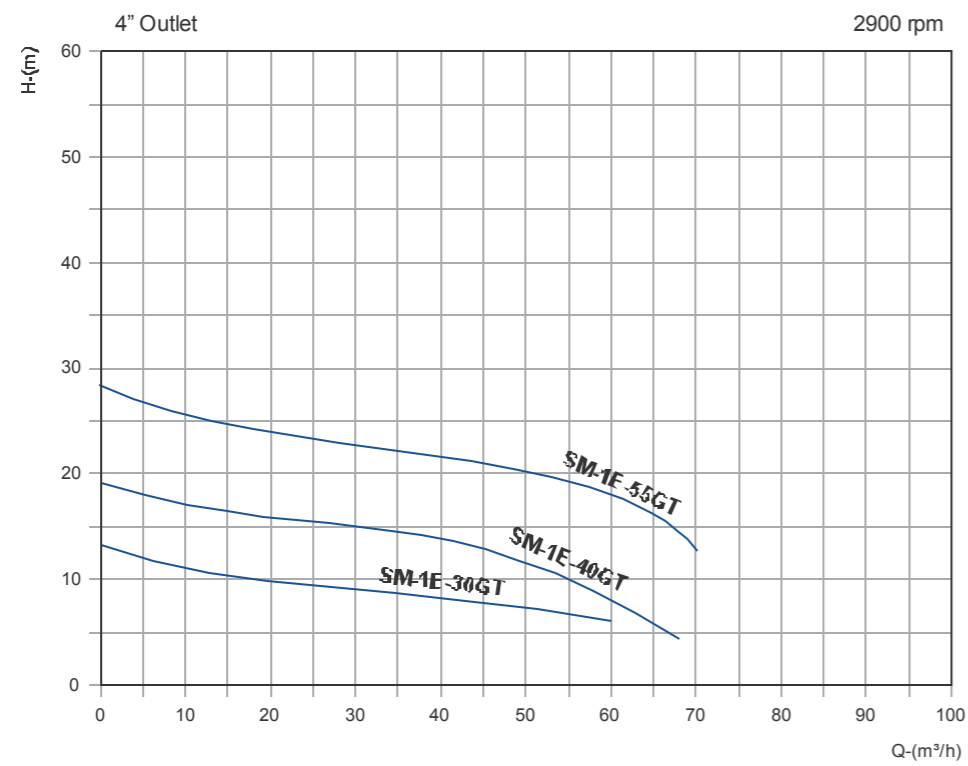
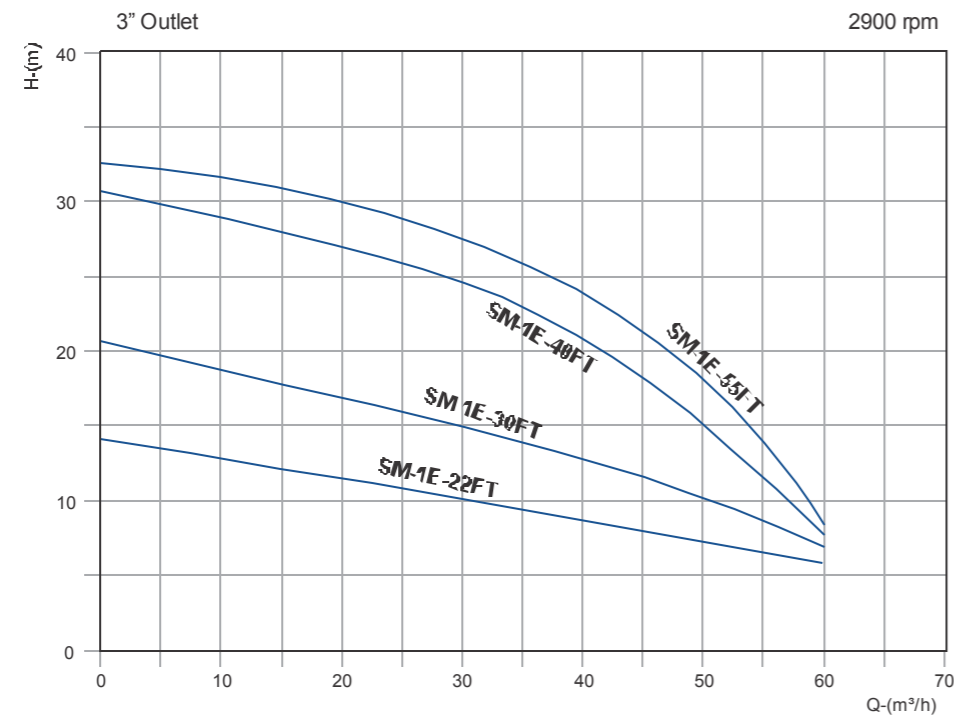

Note: Performance curve are as per specific gravity and viscosity of water.

Performance Curves - SH Series

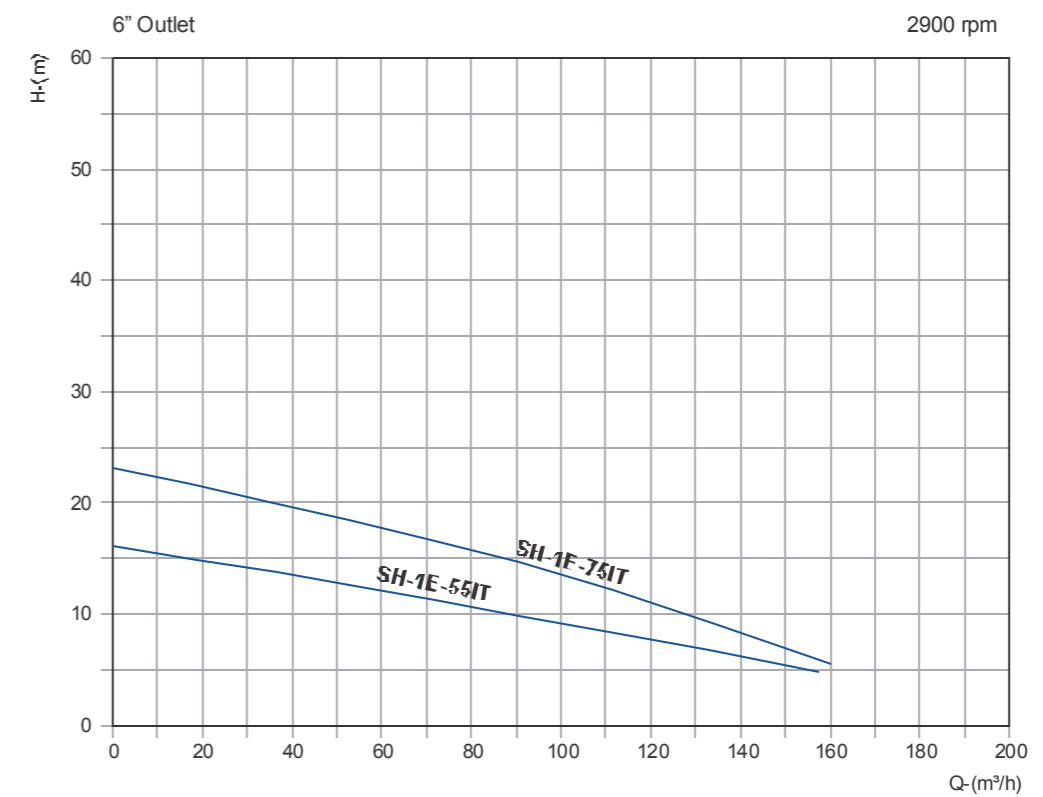
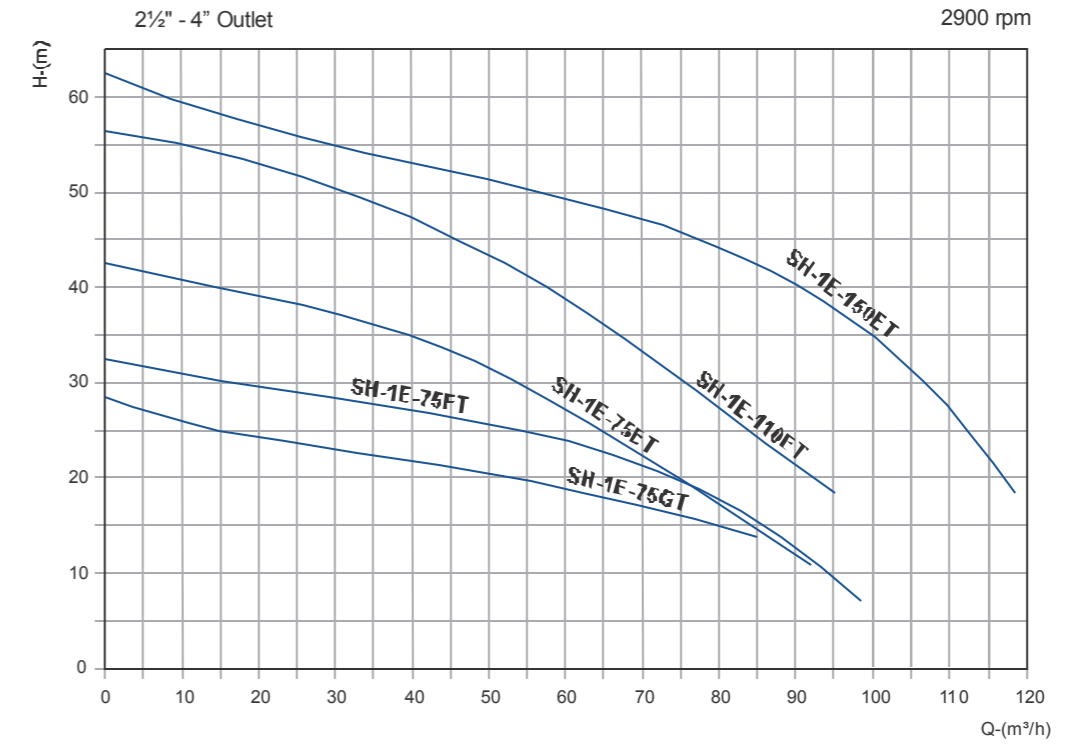

Note: Performance curve are as per specific gravity and viscosity of water.

Performance Curves - SH Series

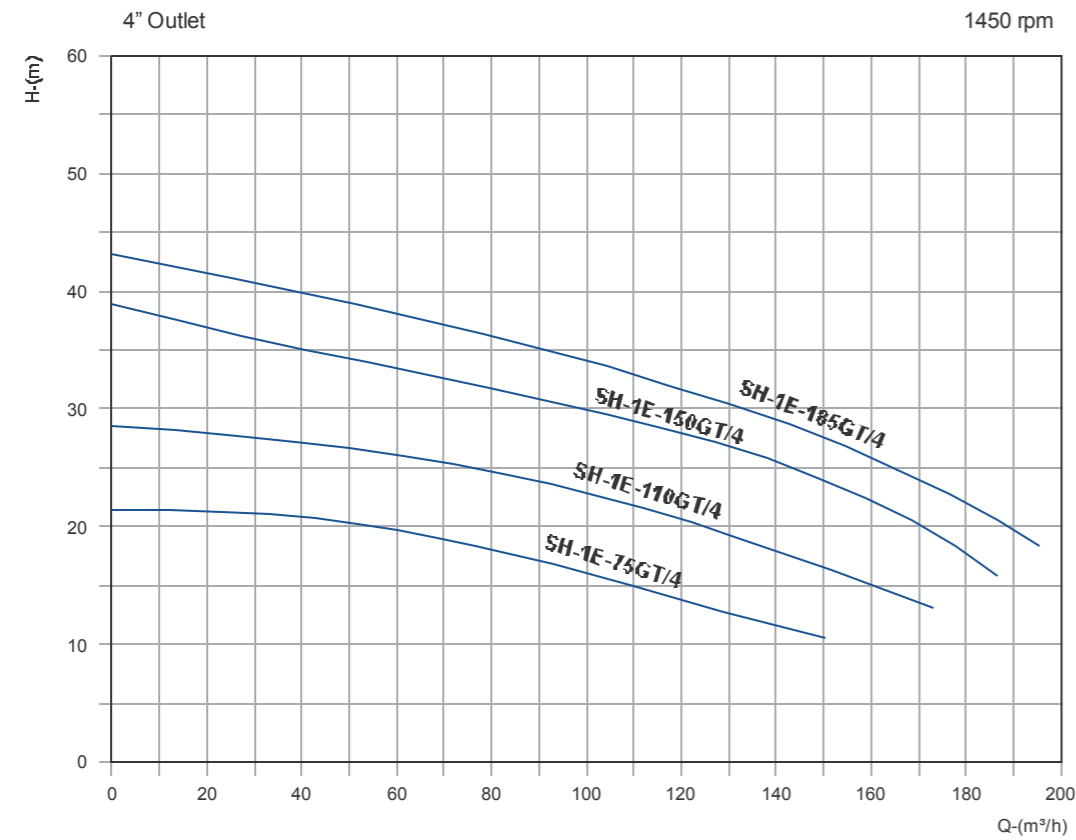

Performance Curves - SH Series

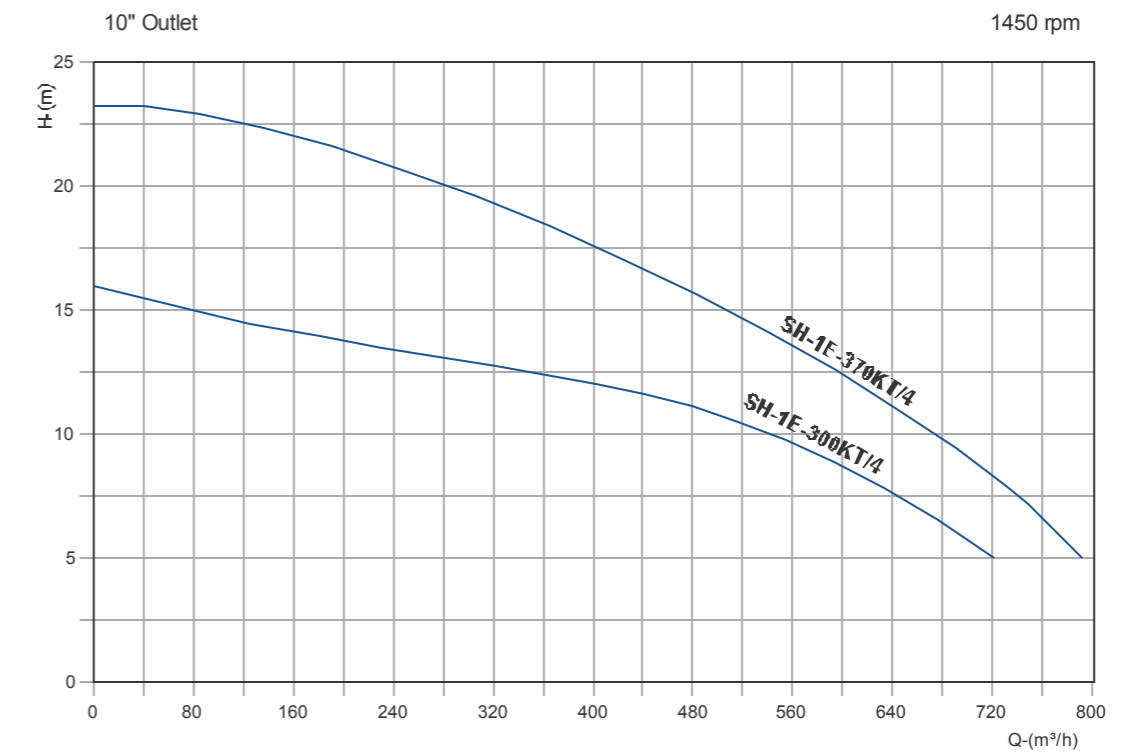
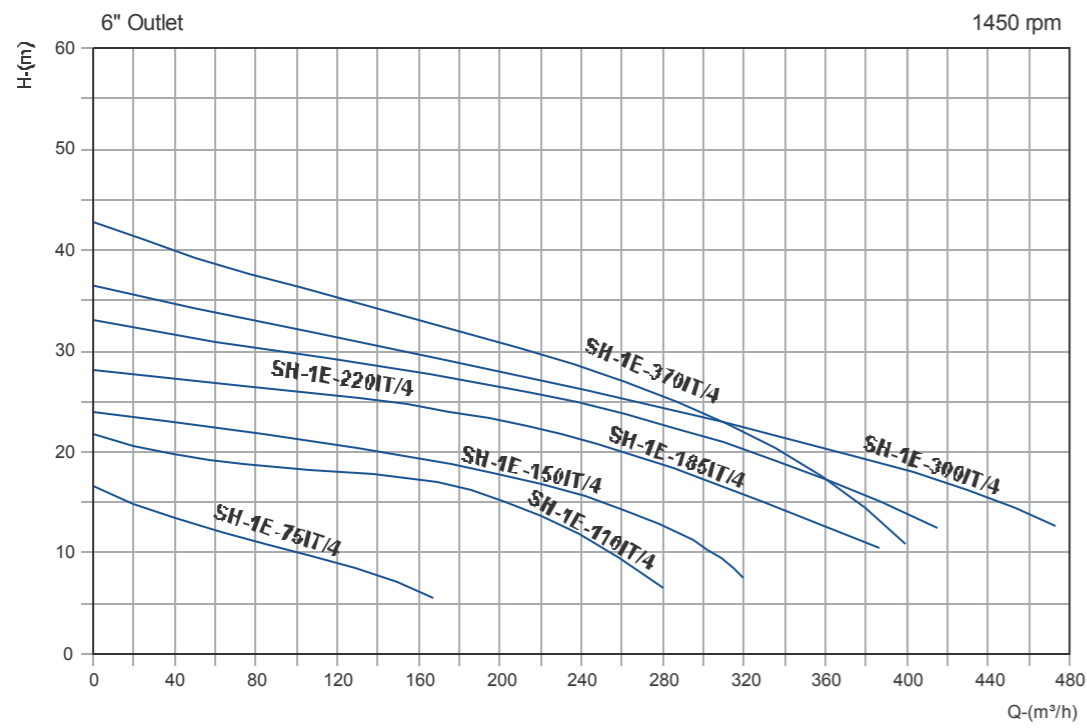
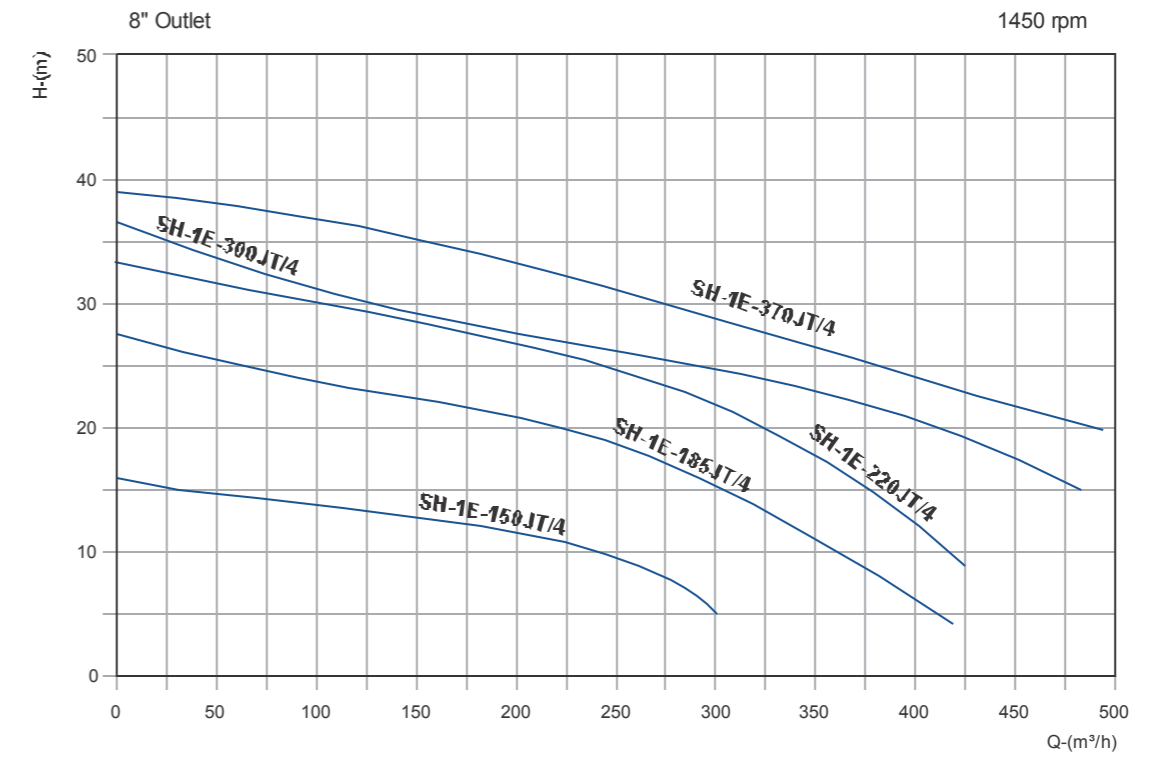

Note : Performance curve are as per specific gravity and viscosity of water.

Note : Performance curve are as per specific gravity and viscosity of water.

Dimensional Details - SM & SH Series

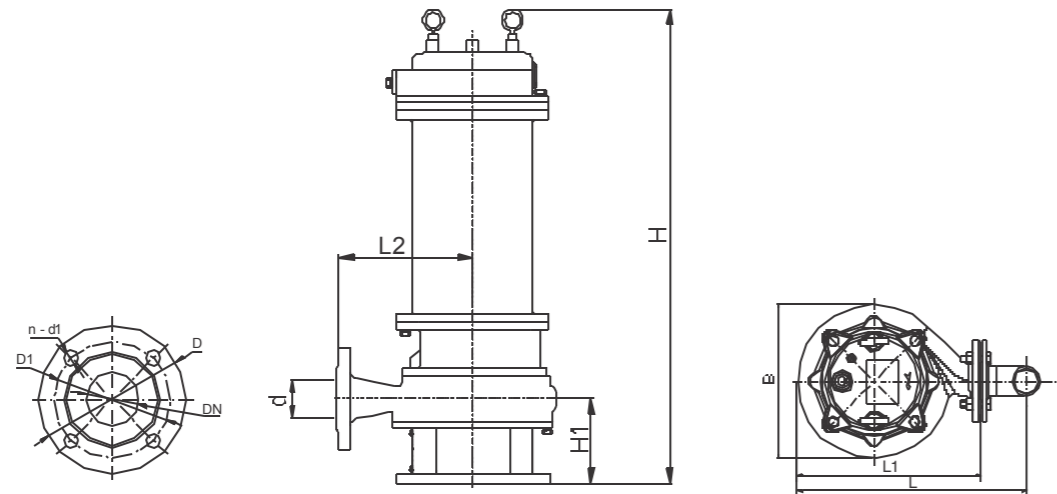

Model	Pump					Flange and elbow					Weight (kg)
	L	L1	L2	H	H1	D	D1	DN	d1	d	
SM-1E-22DT	320	255	150	550	115	φ140	φ110	50	4-φ14	50	36
SM-1E-22ET	325	255	155	560	120	φ160	φ130	65	4-φ14	65	36
SM-1E-22FT	360	285	170	570	125	φ190	φ150	80	4-φ18	80	38
SM-1E-30DT	330	265	155	580	115	φ140	φ110	50	4-φ14	50	50
SM-1E-30ET	330	260	160	585	115	φ160	φ130	65	4-φ14	65	51
SM-1E-30FT	375	300	175	605	125	φ190	φ150	80	4-φ18	80	57
SM-1E-30GT	430	310	185	605	125	φ210	φ170	100	4-φ18	100	62
SM-1E-40DT	380	315	195	615	130	φ140	φ110	50	4-φ14	50	68
SM-1E-40ET	380	310	195	620	135	φ160	φ130	65	4-φ14	65	68
SM-1E-40FT	395	320	195	620	135	φ190	φ150	80	4-φ18	80	68
SM-1E-40GT	460	340	205	655	155	φ210	φ170	100	4-φ18	100	70
SM-1E-55DT	380	315	195	645	135	φ140	φ110	50	4-φ14	50	83
SM-1E-55ET	390	320	210	650	155	φ160	φ130	65	4-φ14	65	85
SM-1E-55FT	395	320	195	650	135	φ190	φ150	80	4-φ18	80	85
SM-1E-55GT	460	340	205	685	155	φ210	φ170	100	4-φ18	100	85
SH-1E-75GT	505	385	250	725	185	φ210	φ170	100	4-φ18	100	138
SH-1E-75IT	580	400	245	735	185	φ240	φ200	150	4-φ18	150	138
SH-1E-75FT	-	-	220	800	185	φ190	φ150	80	4-φ18	80	130
SH-1E-110ET	-	-	310	920	165	φ190	φ150	80	4-φ18	80	230
SH-1E-150ET	-	-	310	935	170	φ160	φ130	65	4-φ14	65	250
SH-1E-75GT/4	-	-	250	780	180	φ210	φ170	100	4-φ18	100	126
SH-1E-75IT/4	-	-	195	810	195	φ240	φ200	150	4-φ18	150	160
SH-1E-110GT/4	-	-	320	925	200	φ210	φ170	100	4-φ18	100	230
SH-1E-110IT/4	-	-	350	1010	230	φ240	φ200	150	4-φ18	150	250
SH-1E-150GT/4	-	-	320	965	200	φ210	φ170	100	4-φ18	100	260
SH-1E-150IT/4	-	-	350	1040	230	φ240	φ200	150	4-φ18	150	272
SH-1E-150JT/4	-	-	350	1065	245	φ320	φ280	200	8-φ18	200	271
SH-1E-185GT/4	-	-	320	980	200	φ210	φ170	100	4-φ18	100	305
SH-1E-185IT/4	-	-	390	1060	260	φ240	φ200	150	4-φ18	150	323
SH-1E-185JT/4	-	-	350	1110	245	φ320	φ280	200	8-φ18	200	349
SH-1E-220IT/4	-	-	390	1090	260	φ240	φ200	150	4-φ18	150	360
SH-1E-220JT/4	-	-	350	1097	245	φ320	φ280	200	8-φ18	200	364
SH-1E-300IT/4	-	-	400	1105	265	φ240	φ200	150	4-φ18	150	370
SH-1E-300JT/4	-	-	360	1230	280	φ320	φ280	200	8-φ18	200	380
SH-1E-300KT/4	-	-	395	1150	275	φ375	φ335	250	12-φ18	250	600
SH-1E-370IT/4	-	-	400	1105	265	φ240	φ200	150	4-φ18	150	650
SH-1E-370JT/4	-	-	360	1230	280	φ320	φ280	200	8-φ18	200	509
SH-1E-370KT/4	-	-	395	1150	275	φ375	φ335	250	12-φ18	250	588

*All dimensions are in mm

*In view of continuous developments, the information / description / specifications / illustrations are subject to change without notice.

Sewage Pump with Cutter - SMC Series

Specifications

Pump Type	SMC Series
Power Range	1.1 - 1.85 kW
Speed	2900 rpm
Versions	1Ph, 230V, 50Hz 3Ph, 380V, 50Hz
Pole	2 Pole
Protection	IP 68
Insulation Class	Class F
Direction of Rotation	Clockwise viewed from driving end
Max. immersion depth	50 m
Max. liquid temperature	40°C
Impeller Type	Semi open multi channel
Outlet Size	2"

Materials of Construction

Part Name	Material
Handle	SS 304
Stator Housing	Cast Iron
Pump Casing	Cast Iron
Shaft	SS 420
Mechanical Seal	Silicon - Ceramic,
Impeller	Cast Iron
Cable	Rubber
Bearing Housing	Casted SS304
Cutter	SS 400C
Oil Seal	NBR



Performance Curves - SMC Series

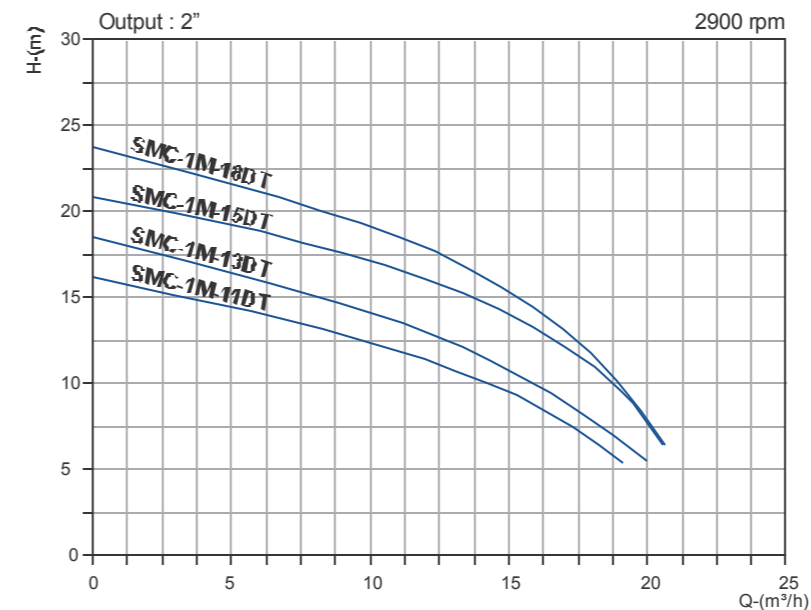

Performance Table

Model	Power - P2		Outlet size (mm)	Max Head (m)	Max Flow (m³/h)	Duty Point	
	kW	HP				Flow (m³/h)	Head (m)
SMC-1M-11DT	1.1	1.5	50	16.5	19	10	12.5
SMC-1M-13DT	1.3	1.8	50	18	20	10	14.5
SMC-1M-15DT	1.5	2	50	21	20	10	17
SMC-1M-18DT	1.85	2.5	50	23.5	20	10	19

*In view of continuous developments, the information / description / specifications / illustrations are subject to change without notice.

Stainless Steel Medium Sewage Pumps - SMS Series



Specifications

Pump Type	SMS Series
Power Range	2.2 kW - 7.5 kW
Speed	2900 rpm
Version	380V, 50Hz, 3Phase AC Supply
Insulation Class	F
Degree of Protection	IP68
Direction of Rotation	Clockwise viewed from driving end
Max. Liquid temperature	40°C
Max. Ambient temperature	40°C
Permissible pH value	4~10
Impeller Type	Closed Double Channel
Max. Solid Handling Capacity	Upto 35 mm
Pump Outlet Size	2", 2½", 3", 4" & 6"

Materials of Construction

Part Name	Material
Stator Housing	Casted SS304
Rotor Shaft	Casted SS304
Bearing Housing	Cast Iron
Pump Casing	Casted SS304
Mechanical Seal	VITON
Impeller	Casted SS304
Oil Seal	VITON
Bracket Casing	Casted SS304
"O" Ring	VITON
Cable	Rubber

*In view of continuous developments, the information / description / specifications / illustrations are subject to change without notice.

Performance Table

Model	Power P2 kW	Input Power-P1 (kW)	Outlet Size in inches	H max in m	Duty Point		Max. Solid Passage (mm)	F.L. Current (A)	Eff. %	Weight (kg)
					Flow (m³/h)	Head (m)				
SMS-5E-22DT	2.2	3.03	2	23.5	15	19.5	20	4.7	45.7	36.1
SMS-5E-22ET	2.2	3.03	2.5	19	25	16	25	4.7	49.7	38.3
SMS-5E-22FT	2.2	3.03	3	14	40	9	25	4.7	54.5	40.8
SMS-5E-22GT	2.2	3.03	4	12	50	7	30	4.7	54.5	43.2
SMS-5E-30DT	3	3.98	2	31	15	25.5	20	6.4	45.7	40
SMS-5E-30ET	3	3.98	2.5	24.5	25	20.5	25	6.4	49.4	41.8
SMS-5E-30FT	3	3.98	3	21	40	14.5	25	6.4	52.6	44.3
SMS-5E-30GT	3	3.98	4	20	50	12.5	30	6.4	54.5	47
SMS-5E-40DT	4	5.23	2	38	15	33	20	8.2	45.7	39.8
SMS-5E-40ET	4	5.23	2.5	30.5	25	25.5	25	8.2	49.4	45.6
SMS-5E-40FT	4	5.23	3	23	40	20	25	8.2	52.6	47.8
SMS-5E-40GT	4	5.23	4	23	50	17	30	8.2	54.5	51
SMS-5E-75DT	7.5	9.39	2	45	20	39	20	15	48	71
SMS-5E-75ET	7.5	9.39	2.5	38	30	32.5	25	15	50.8	72.7
SMS-5E-75FT	7.5	9.39	3	27	45	22.5	30	15	54.5	75.4
SMS-5E-75GT	7.5	9.39	4	22.5	80	14.5	30	15	56.5	77.3
SMS-5E-75IT	7.5	9.39	6	18	100	9	35	15	58.8	88

Performance Curves

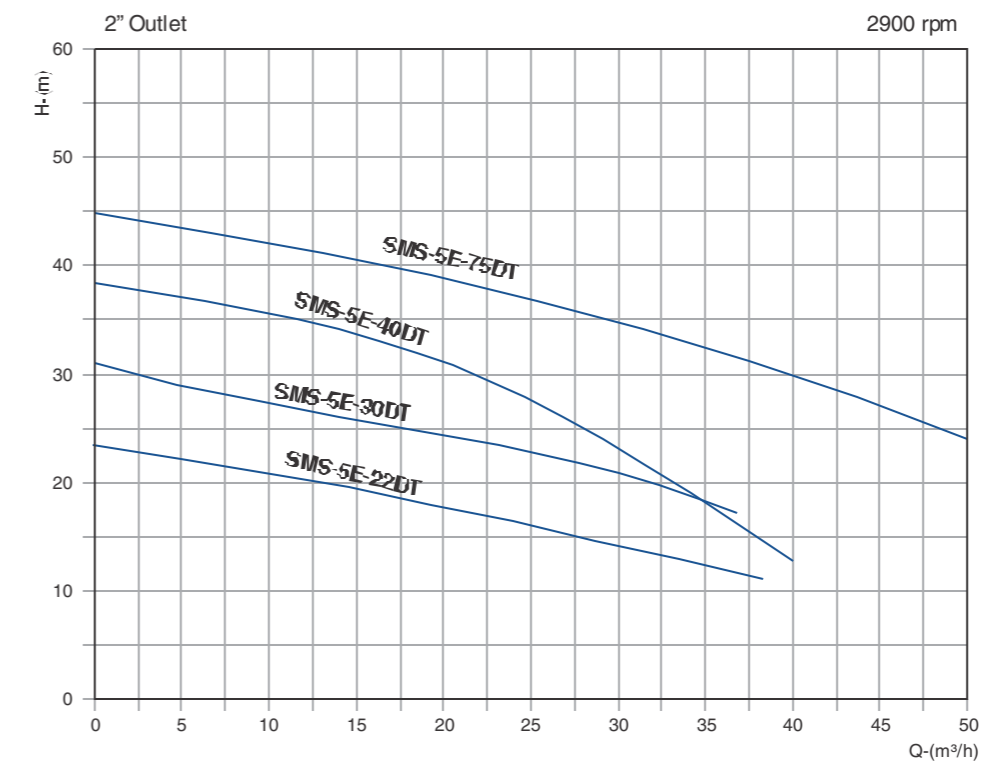

Note: Performance curve are as per specific gravity and viscosity of water.

Performance Curves

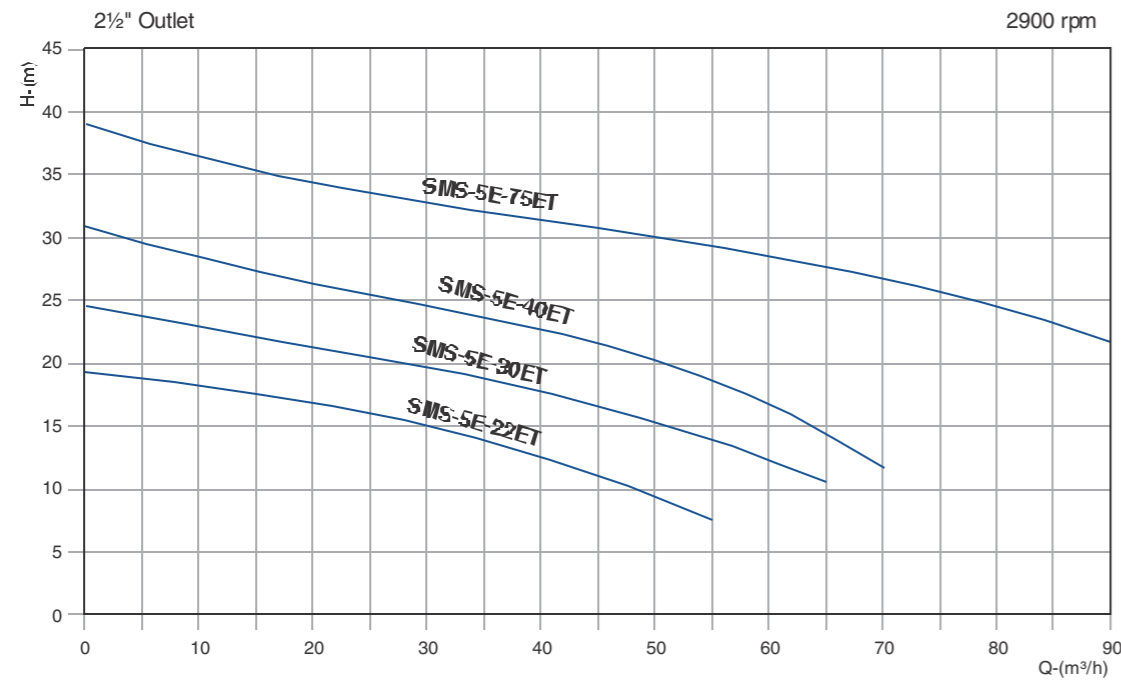

Performance Curves

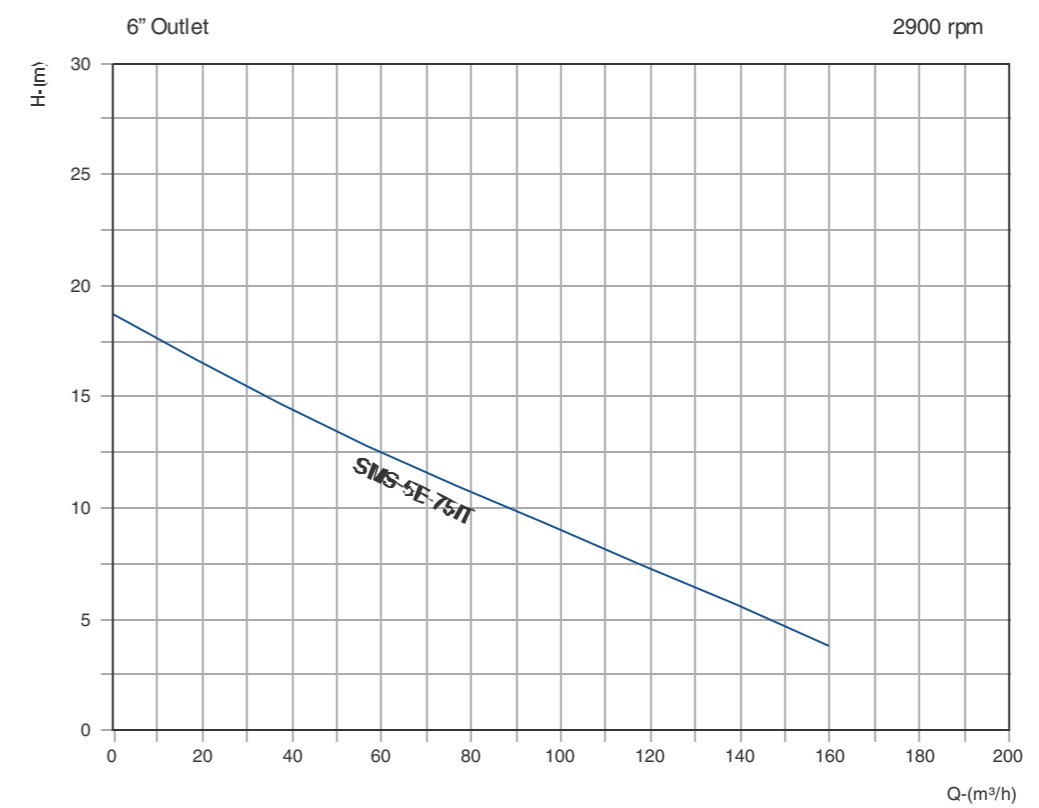
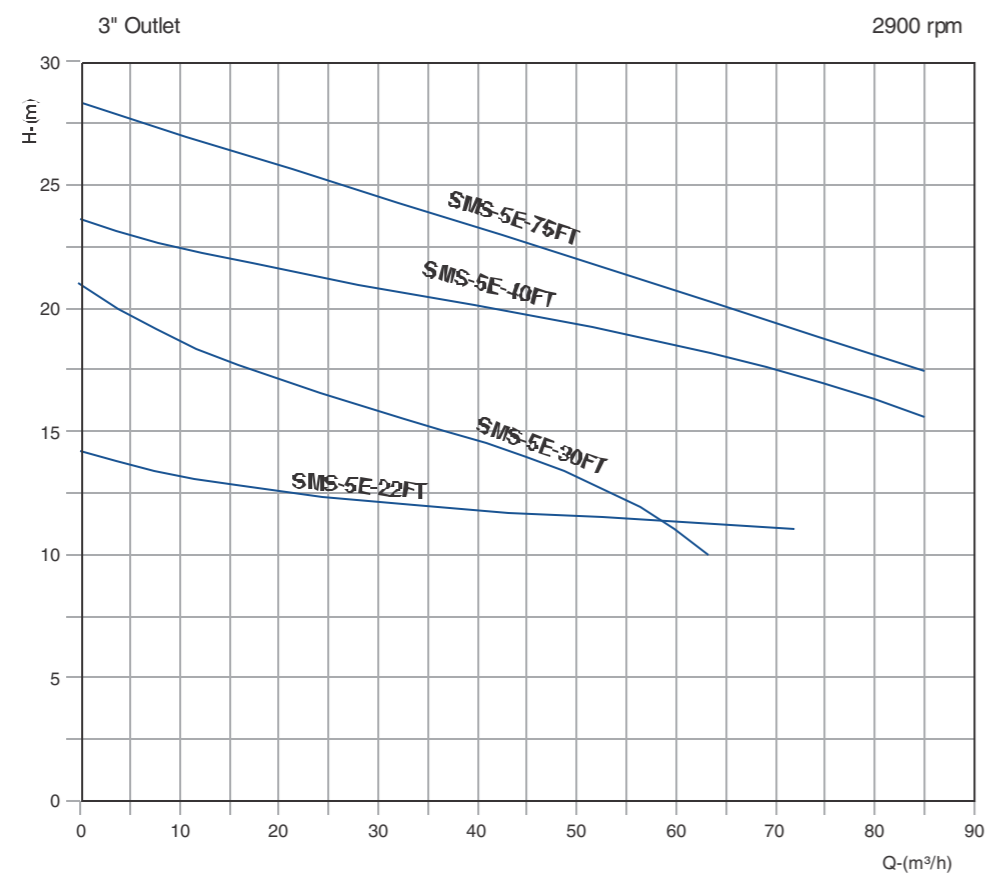
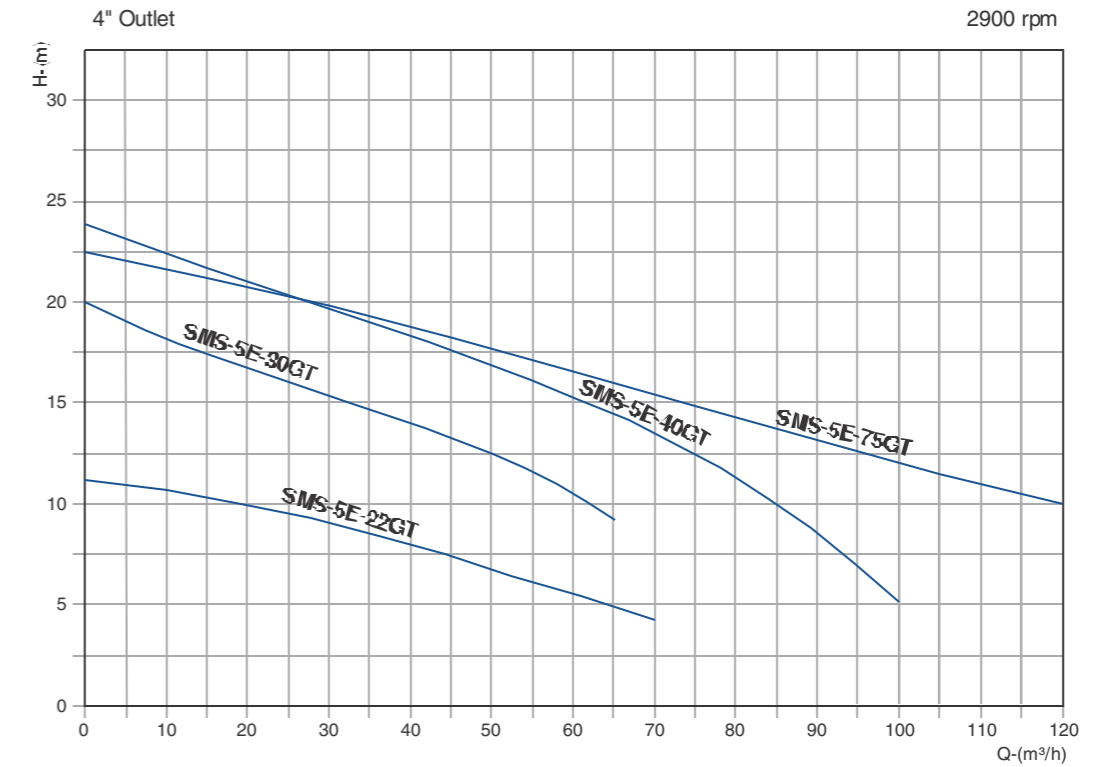

Note : Performance curve are as per specific gravity and viscosity of water.

Note : Performance curve are as per specific gravity and viscosity of water.

Dimensional details

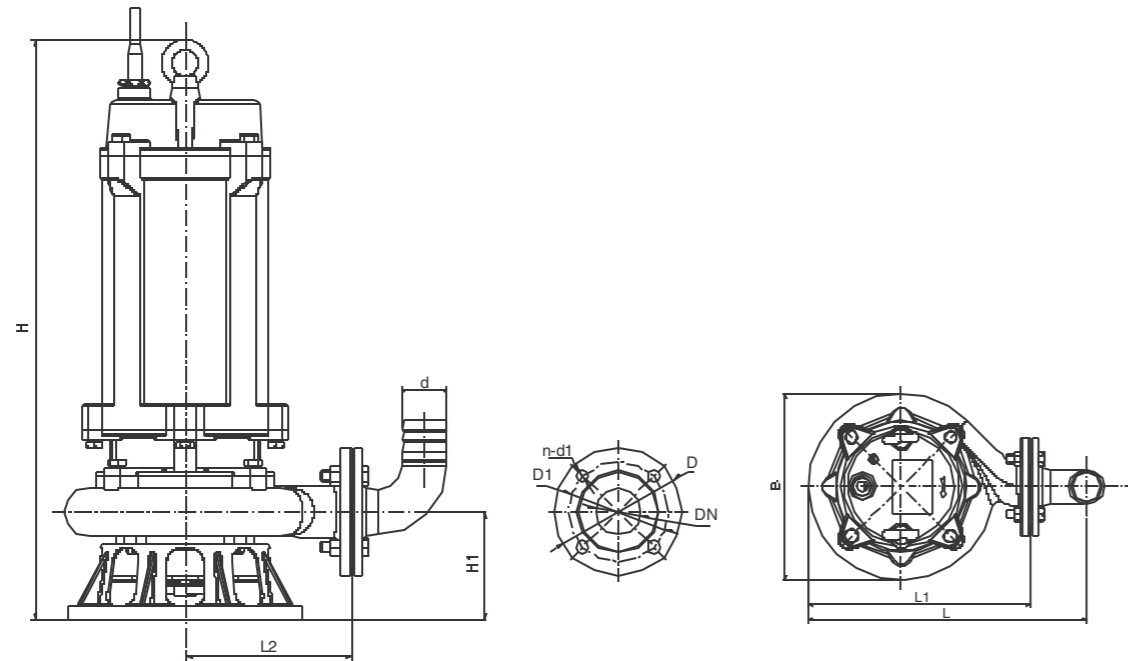

Model	Pump						Flange and elbow					Weight (kg)
	L	L1	L2	B	H	H1	D	D1	DN	n-d1	d	
SMS-5E-22DT	340	262	154	216	543	112	φ140	φ110	φ50	4-φ14	φ50	36.1
SMS-5E-22ET	358	276	166	220	543	114	φ160	φ130	φ65	4-φ14	φ65	38.3
SMS-5E-22FT	381	279	166	226	549	117	φ190	φ150	φ80	4-φ18	φ76	40.8
SMS-5E-22GT	417	297	176	242	565	125	φ210	φ170	φ100	4-φ18	φ100	43.2
SMS-5E-30DT	359	281	164	234	561	112	φ140	φ110	φ50	4-φ14	φ50	40
SMS-5E-30ET	367	285	166	238	565	114	φ160	φ130	φ65	4-φ14	φ65	41.8
SMS-5E-30FT	381	279	166	226	574	117	φ190	φ150	φ80	4-φ18	φ76	44.3
SMS-5E-30GT	417	297	176	242	590	125	φ210	φ170	φ100	4-φ18	φ100	47
SMS-5E-40DT	359	281	164	234	586	112	φ140	φ110	φ50	4-φ14	φ50	39.8
SMS-5E-40ET	367	285	166	238	590	114	φ160	φ130	φ65	4-φ14	φ65	45.6
SMS-5E-40FT	381	279	166	226	599	117	φ190	φ150	φ80	4-φ18	φ76	47.8
SMS-5E-40GT	417	297	176	242	615	125	φ210	φ170	φ100	4-φ18	φ100	51
SMS-5E-75DT	394	316	184	264	679	118	φ140	φ110	φ50	4-φ14	φ50	71
SMS-5E-75ET	417	333	196	274	693	125	φ160	φ130	φ65	4-φ14	φ65	72.7
SMS-5E-75FT	441	337	196	282	701	129	φ190	φ150	φ80	4-φ18	φ76	75.4
SMS-5E-75GT	464	342	196	292	711	134	φ210	φ170	φ100	4-φ18	φ100	77.3
SMS-5E-75IT	521	373	220	306	726	142	φ265	φ225	φ150	8-φ18	φ150	88

*All dimensions are in mm
 *In view of continuous developments, the information / description / specifications / illustrations are subject to change without notice.

GUIDE RAIL SYSTEM



C.R.I. Guide Rail System consists of a base elbow, guide rails, top bracket, sliding hook & chains.

Features

Guide Rail System is used for easy & handle free installation. Further this helps for raising / lowering the pump quickly & conveniently for maintenance without entering the sump and without disturbing the pipe connections..

Applications

Waste water pumping stations where the pumps are subject to regular maintenance & inspection such as Effluent Treatment Plants (ETP), Sewage Treatment Plants (STP) & Sewage Pits.

* All our Medium & Heavy Sewage pump can be supplied with guide rail system.

Auto - Coupling Installation

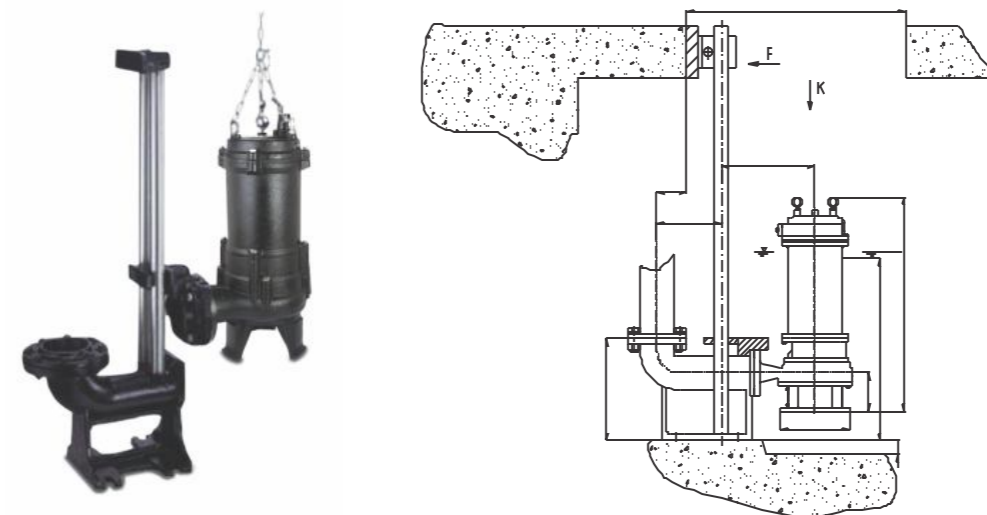

STAINLESS STEEL DRAINAGE PUMPS - DMS SERIES (CONSTRUCTION DEWATERING)

Specifications

Pump Type	DMS Session
Power Range	2.2 - 22 kW
Speed	2900 rpm
Versions	1Ph 230V, 50Hz 3Ph, 380V, 50Hz
Pole	2 Pole
Protection	IP 68
Insulation Class	Class F
Max. immersion depth	5m
Max. liquid temperature	40°C
Impeller Type	Closed Double Channel



Materials of Construction

Pump Name	Material
Outer Casing	SS 304
Pump Casing	SS 304
Shaft	SS 420
Mechanical Seal	Carbon - Ceramic
Impeller	SS 304
Cable	H07RN-F
Handle	Stainless Steel
Strainer	SS 304

Performance Table

Model	Power - P2		Outlet size (mm)	Max Head (m)	Max Flow (m³/h)	Duty Point		Weight (kg)
	kW	HP				Flow (m³/h)	Head (m)	
DMS-5E-22ET	2.2	3	65	30	33	15	25	28
DMS-5E-22GT	2.2	3	100	10	78	65	7	29
DMS-5E-30FT	3	4	80	20	48	40	16	42
DMS-5E-30GT	3	4	100	13	78	65	10	33
DMS-5E-40ET	4	5.5	65	40	50	20	35	47
DMS-5E-40FT	4	5.5	80	25	70	40	21	39
DMS-5E-55HT	5.5	7.5	120	15	120	100	12	85
DMS-5E-75IT	7.5	10	150	15	180	160	11	106
DMS-5E-110HT	11	15	120	33	130	100	25	165
DMS-5E-150KT	15	20	250	20	280	250	12	195
DMS-5E-220IT	22	30	150	47	140	120	40	272

*In view of continuous developments, the information / description / specifications / illustrations are subject to change without notice.

Performance Curves

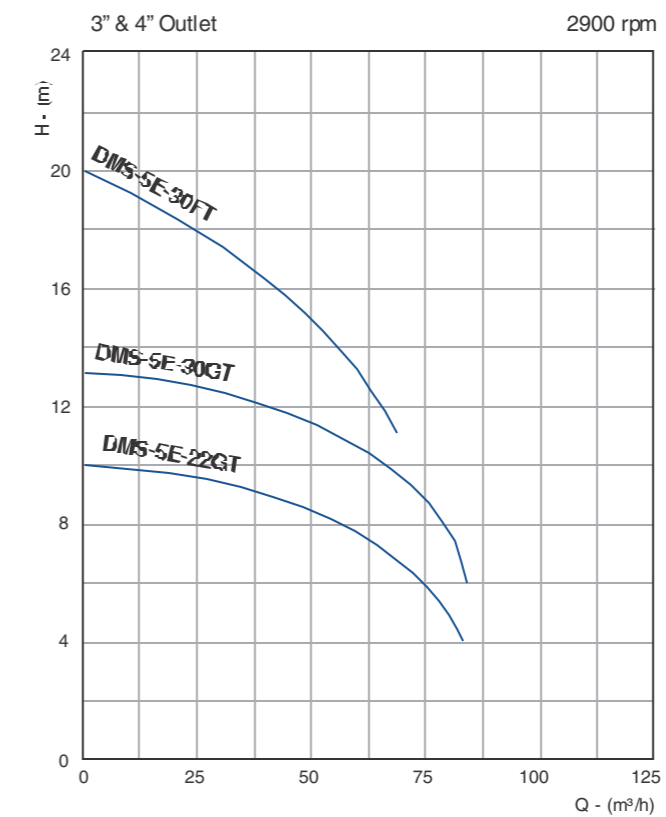
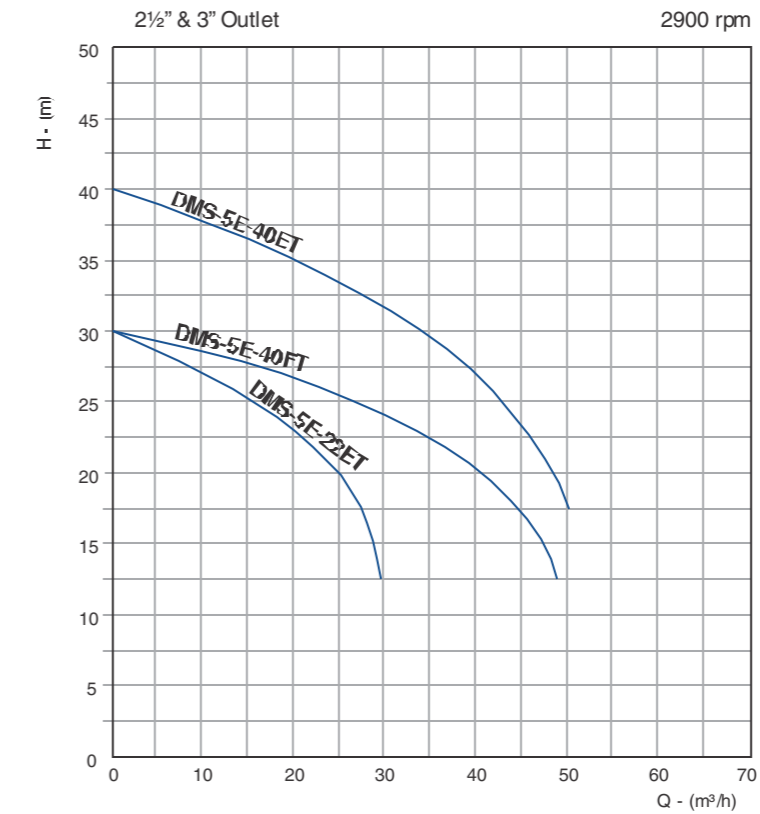

Note: Performance curve are as per specific gravity and viscosity of water.

Performance Curves

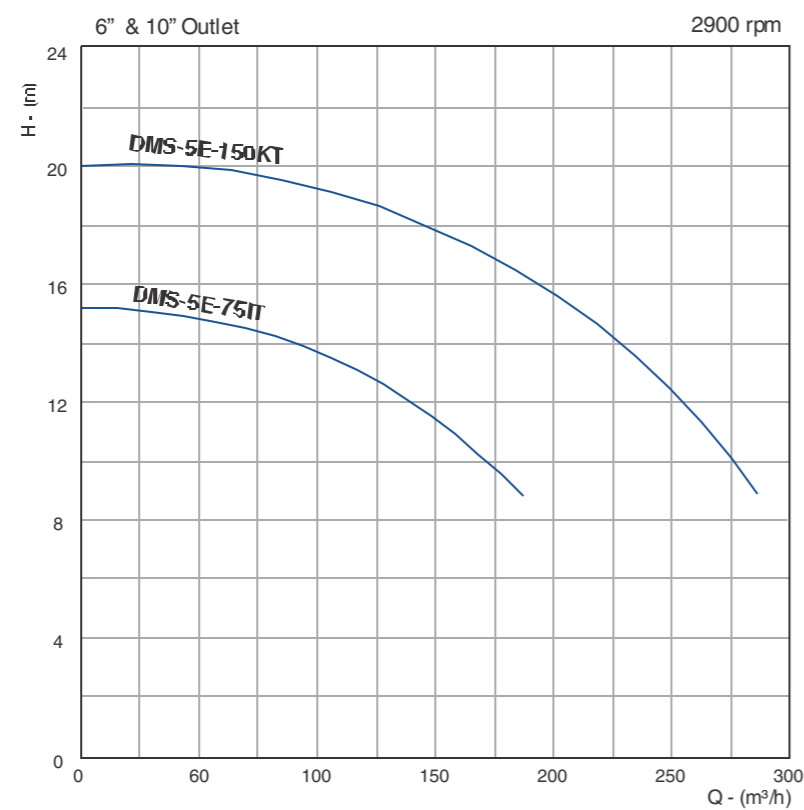
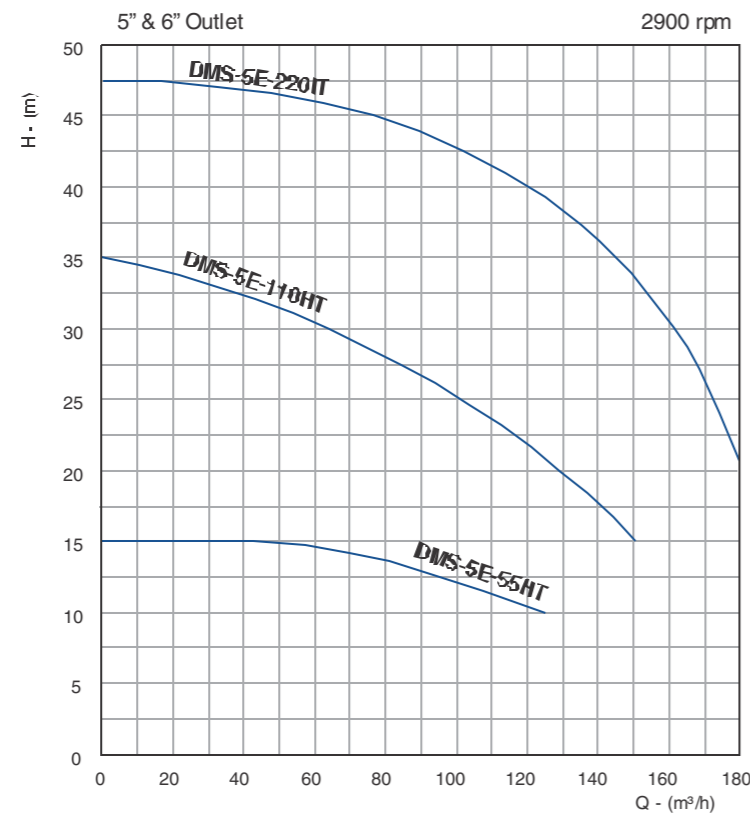

Note : Performance curve are as per specific gravity and viscosity of water.

DRAINAGE PUMPS - DM SERIES (CONSTRUCTION DEWATERING)

Specifications

Pump Type	DM - 1M Series	DM - 2M Series
Power Range	1.5 - 15 kW	0.25 - 5.5 kW
Speed	2900 rpm	2900 rpm
Versions	3Ph, 380V, 50Hz	1Ph, 230V, 50Hz 3Ph, 380V, 50Hz
Pole	2 Pole	2 Pole
Protection	IP 68	IP 68
Insulation Class	Class F	Class F
Max. immersion depth	50m	Upto 0.75 kW : 10m 1.5 to 5.5 kW : 50m
Max. liquid temperature	40°C	40°C
Impeller Type	Semi open multi channel	Semi open multi channel
Solid Handling Capacity	Upto 11.5 mm	Upto 8.5mm
Outlet Size	2", 3", 4" & 6"	2", 3" & 4"



DM - 2M Series



DM - 1M Series

Materials of Construction

Pump Type	DM - 1M Series	DM - 2M Series
Motor Body	Cast Iron	SS 304
Pump Casing	Cast Iron	Cast Iron
Shaft	SS 420	SS 420
Mechanical Seal	SiC - SiC	SiC-SiC / Carbon - Ceramic
Impeller	Cast Iron	Cast Iron
Cable	2PNCT-F	H07RN - F
Strainer	Mild Steel	SS 304
Hose Coupler	Cast Iron	ABS / SS 304

Performance Table - DM-2M Series (*All DM-2M Models are supplied with float options)

Model	Power - P2		Max. Solid Passage (mm)	Outlet size (mm)	Max Head	Max Flow	Duty Point		Dimensions (mm)		Weight (kg)
	kW	HP					Flow (m³/h)	Head (m)	Height	OD	
DM-2M-15DT	1.5	2	8.5	50	22	27	15	15	537	240	32.5
DM-2M-15FT	1.5	2	8.5	80	14.5	40	20	12	537	240	32.5
DM-2M-22DT	2.2	3	8.5	50	26	27	20	18	572	240	36
DM-2M-22FT	2.2	3	8.5	80	21	50	25	15	572	240	36
DM-2M-37DT	3.7	5	8.5	50	34	29	20	24	518	270	45
DM-2M-37FT	3.7	5	8.5	80	29	55	30	20	518	270	45
DM-2M-37GT	3.7	5	8.5	100	18	90	45	13	518	270	45
DM-2M-55FT	5.5	7.5	8.5	80	32	70	40	24	558	270	50
DM-2M-55GT	5.5	7.5	8.5	100	23	105	55	16	558	270	50

Performance Table - DM - 1M Series

Model	Power - P2		Outlet size (mm)	Max.Solid Passage (mm)	Max Head (m)	Max Flow (m³/h)	Duty Point	
	kW	HP					Flow (m³/h)	Head (m)
DM-1M-15DT	1.5	2	50	8.5	22	27	15	15
DM-1M-22DT	2.2	3	50	8.5	26	27	20	18
DM-1M-37DT	3.7	5	50	8.5	34	29	20	24
DM-1M-15FT	1.5	2	80	8.5	14.5	40	20	12
DM-1M-22FT	2.2	3	80	8.5	21	50	25	15
DM-1M-37FT	3.7	5	80	8.5	29	55	30	20
DM-1M-55FT	5.5	7.5	80	8.5	32	70	40	24
DM-1M-37GT	3.7	5	100	8.5	18	90	40	13
DM-1M-55GT	5.5	7.5	100	8.5	23	105	55	16
DM-1M-75GT	7.5	10	100	11.5	40	84	50	26
DM-1M-110GT	11	15	100	11.5	48.5	86.4	50	28
DM-1M-150GT	15	20	100	11.5	56	86.4	60	42
DM-1M-75IT	7.5	10	150	19.5	31	124.8	70	19
DM-1M-110IT	11	15	150	19.5	32	147	80	22
DM-1M-150IT	15	20	150	19.5	40	156	100	30

*In view of continuous developments, the information / description / specifications / illustrations are subject to change without notice.

Performance Curves - DM Series

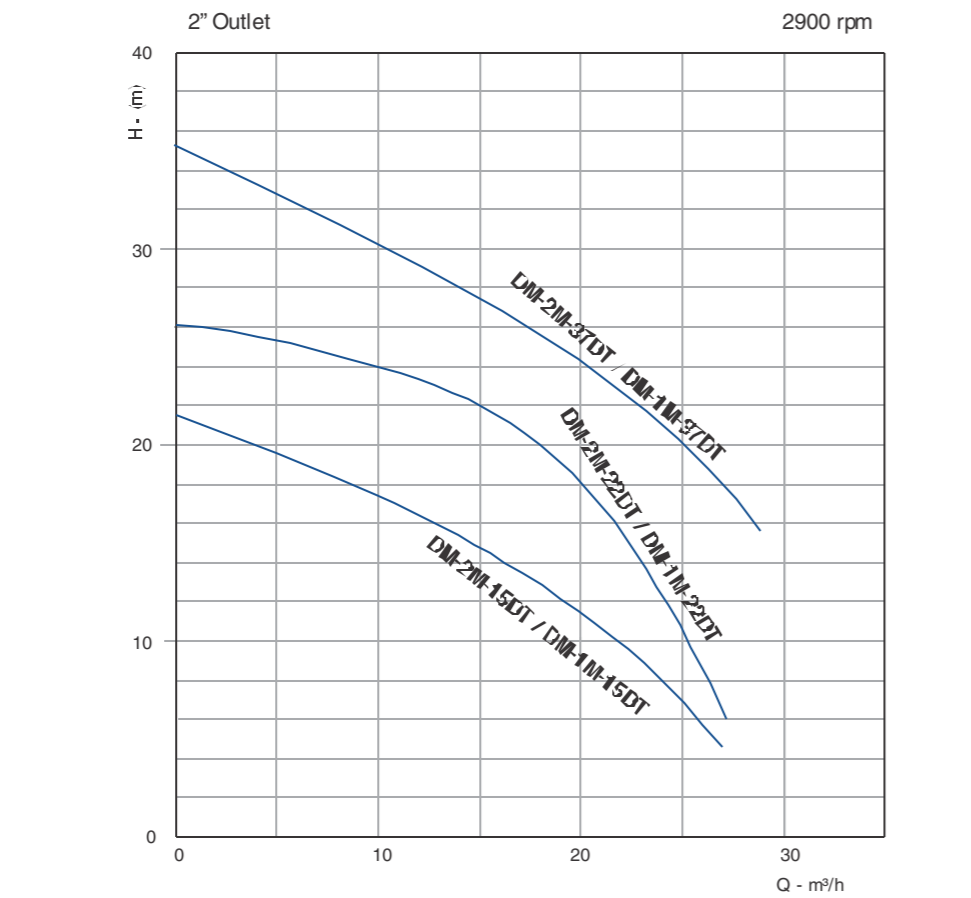

Performance Curves - DM Series

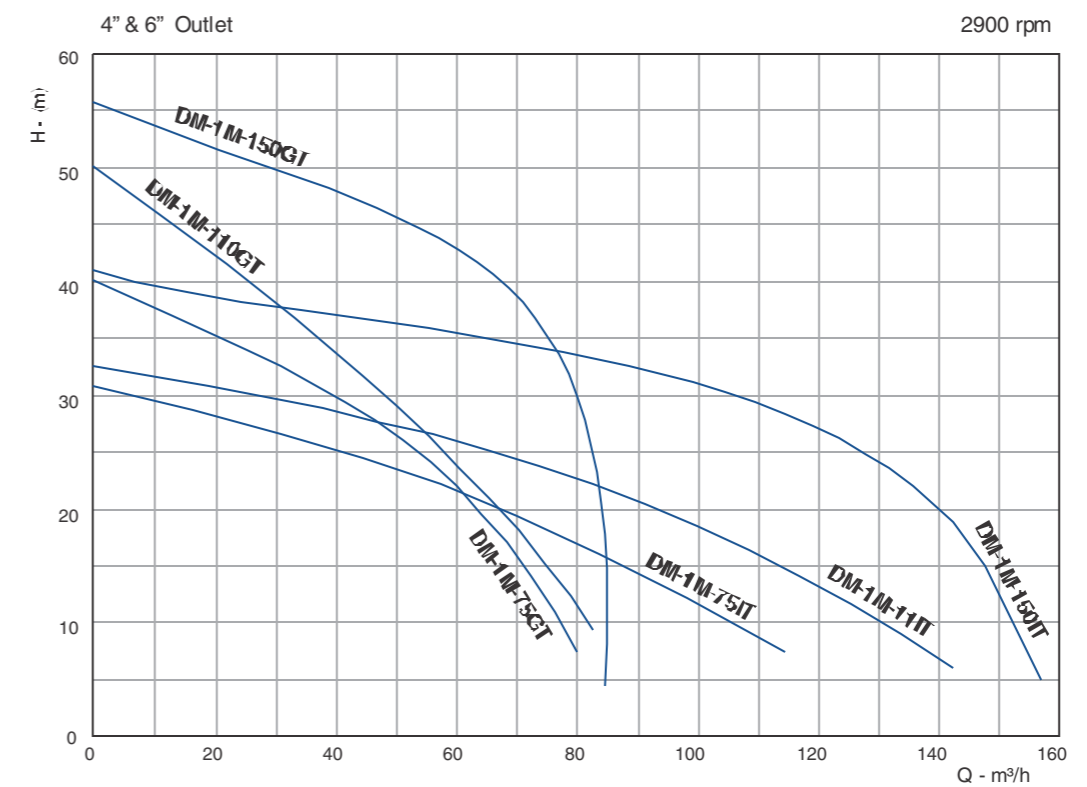
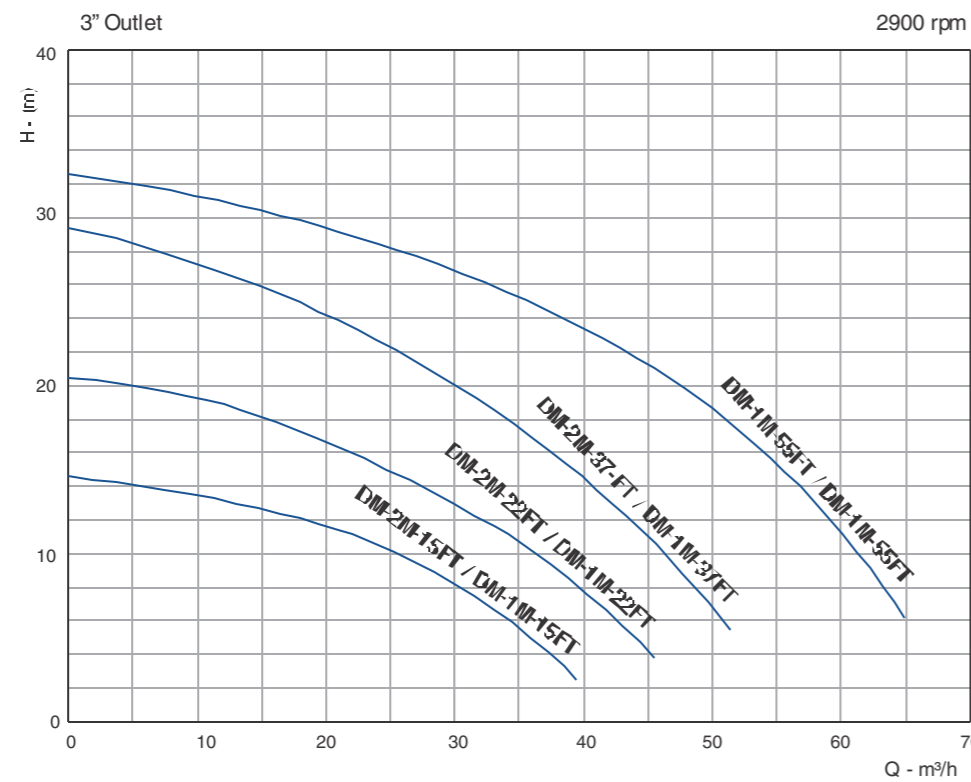
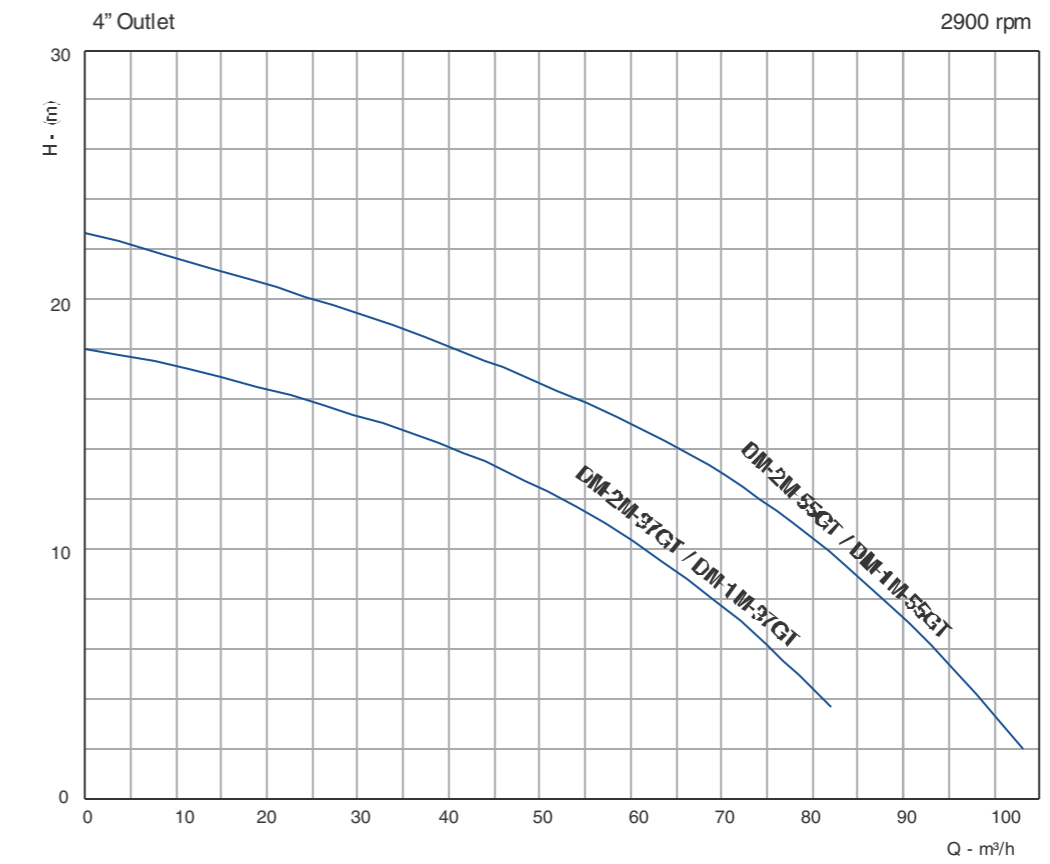

Note : Performance curve are as per specific gravity and viscosity of water.

Note : Performance curve are as per specific gravity and viscosity of water.

Cut Sectional Drawing - DM - 1M Series

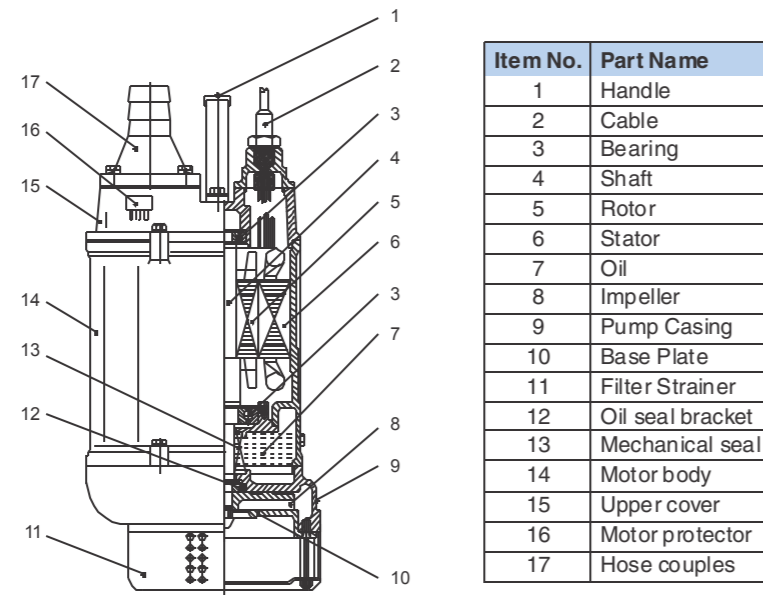

Dimensional Details - DM - 1M Series

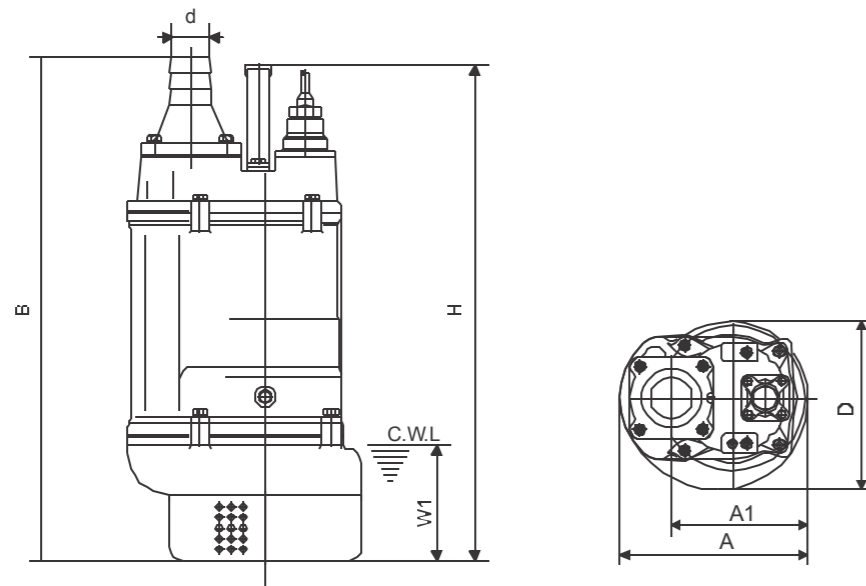

Model	d	A	A1	B	D	H	W1
DM-1M-15DT	50	235	173	517	216	486	120
DM-1M-15FT	80	235	173	517	216	486	120
DM-1M-21DT	50	235	173	517	216	486	120
DM-1M-22FT	80	235	173	517	216	486	120
DM-1M-37DT	50	283	208	628	252	638	150
DM-1M-37FT	80	283	208	628	252	638	150
DM-1M-37GT	100	283	208	642	252	638	150
DM-1M-55FT	80	306	218	671	259	688	150
DM-1M-55GT	100	306	218	686	259	688	150
DM-1M-75GT	100	330	240	764	314	676	190
DM-1M-110GT	100	373	255	807	350	695	190
DM-1M-75IT	150	330	240	790	314	676	190
DM-1M-110IT	150	373	255	807	350	695	190

*In view of continuous developments, the information / description / specifications / illustrations are subject to change without notice.

SUBMERSIBLE SLURRY PUMPS - DMA SERIES (With Agitator)

Specifications

Pump Type	DMA Series
Power Range	4 - 9 kW
Speed	1450 rpm
Versions	3Ph, 380V, 50Hz
Pole	4 Pole
Protection	IP 68
Insulation Class	Class F
Max. immersion depth	30m
Max. liquid temperature	40°C
Impeller Type	Semi open multi channel
Solid Handling Capacity	Upto 30 mm
Outlet Size	3", 4" & 6"



Materials of Construction

Part Name	Material
Motor Body	Cast Iron
Pump Casing	Cast Iron
Shaft	SS 420
Mechanical Seal	SiC - SiC
Impeller	Cast Iron
Cable	2PNCT-F
Strainer	Mild Steel
Hose Coupler	Cast Iron

Performance Table

Model	Power - P2		Outlet size (inches)	Max.Solid (mm)	Max Head (m)	Max Flow (m³/h)	Duty Point	
	kW	HP					Flow (m³/h)	Head (m)
DMA-1M-40FT/4	4	5.5	3	30	14.8	100	50	11
DMA-1M-60GT/4	6	8	4	30	16.9	150	75	11
DMA-1M-90IT/4	9	12	6	30	21.5	170	100	15

Performance Curves

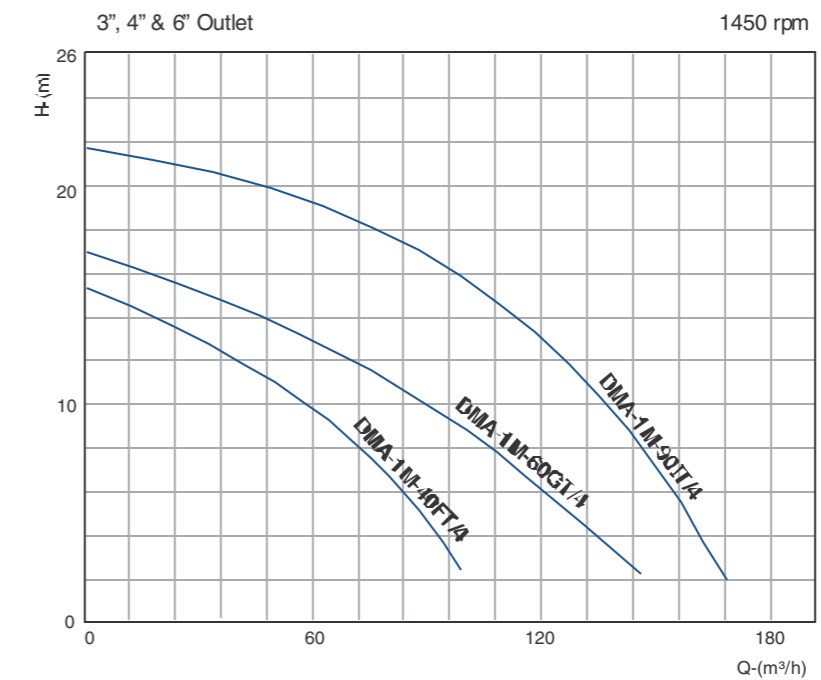

Note : Performance curve are as per specific gravity and viscosity of water.

Cut Sectional Drawing

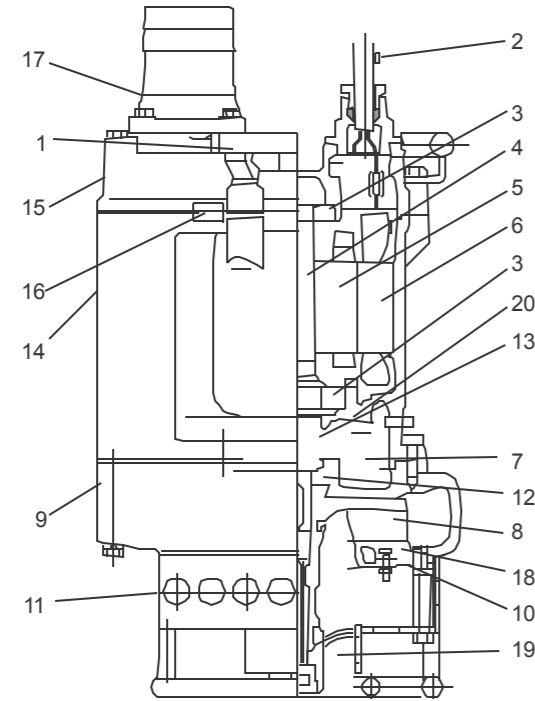

Part No.	Name
1	Handle
2	Cable
3	Bearing
4	Shaft
5	Rotor
6	Stator
7	Lube Oil
8	Impeller
9	Pump Casing
10	Base Plate
11	Strainer
12	Oil Seal Bracket
13	Mechanical Seal
14	Motor Body
15	Upper Housing
16	Motor protection
17	Hose Coupler
18	Suction plate
19	Agitator
20	Bearing Housing

Dimensional Details

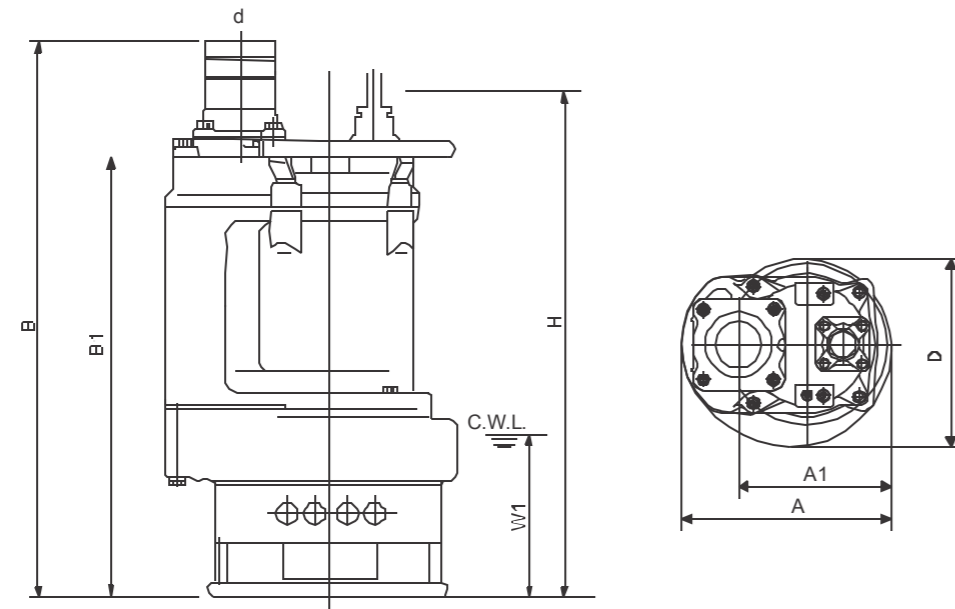

Model	d	A	A1	B	B1	D	H	W1
DMA-1M-40FT/4	80	350	260	765	666	326	730	250
DMA-1M-60GT/4	100	415	305	848	688	373	730	250
DMA-1M-90IT/4	150	434	324	869	709	407	776	250

*In view of continuous developments, the information / description / specifications / illustrations are subject to change without notice.